

wear parts HEM



INT



Wear parts HEM

Cross section HEM

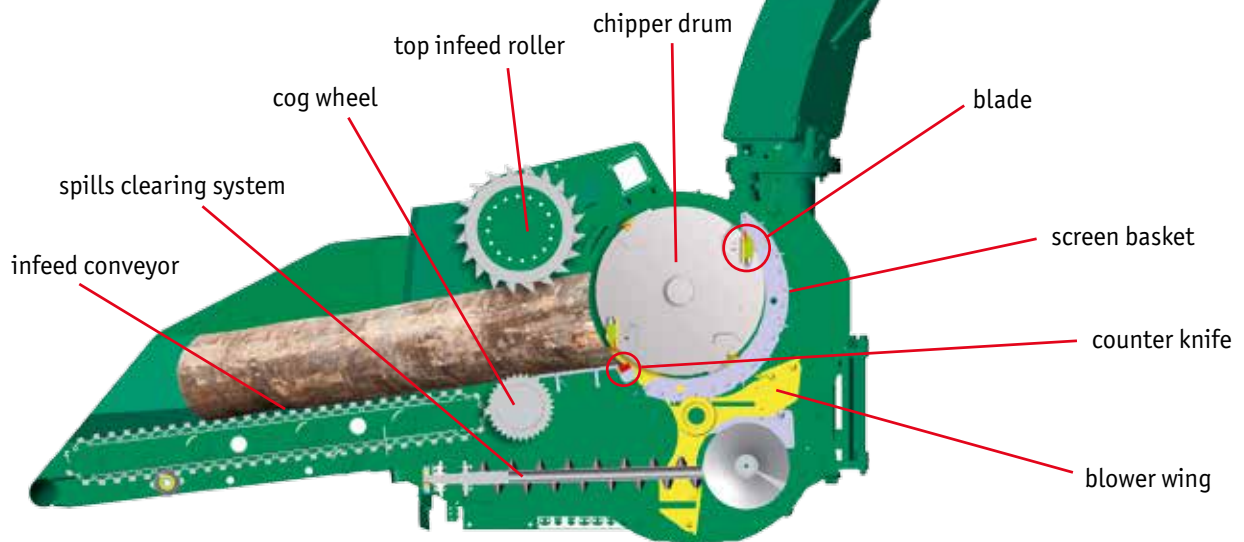

Pre-grip distance from drum body to blade cutter

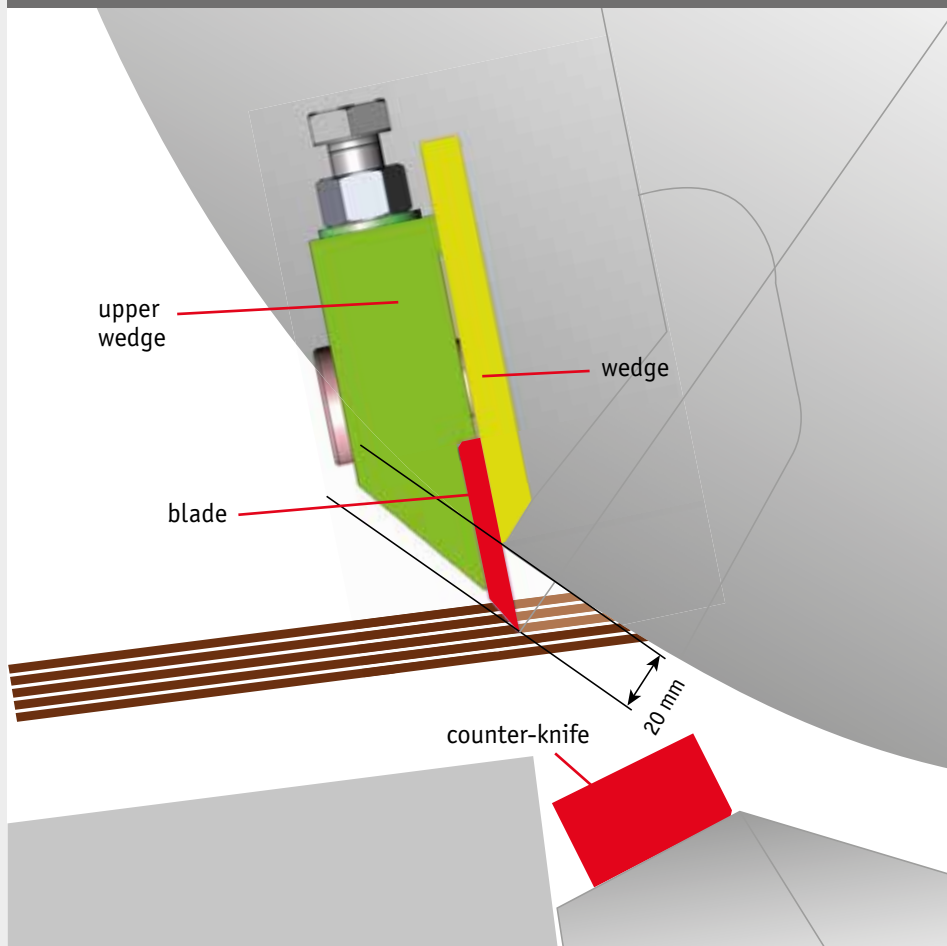

Use of different upper wedge and counter-knife increases distance from drum body to blade cutter:

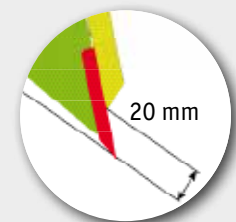

Standard size 20 mm

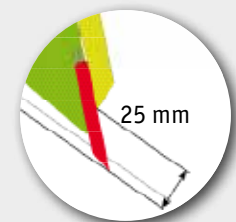

Special size 25 mm



Pre-grip enlargement: please ask our service department to give you a quotation.

JENZ blade system

Blade with equipment

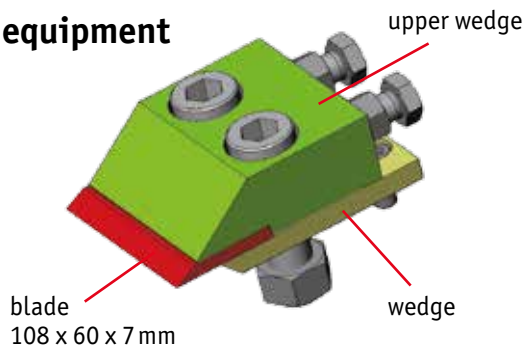

Blade with equipment hardwood knife, reinforced

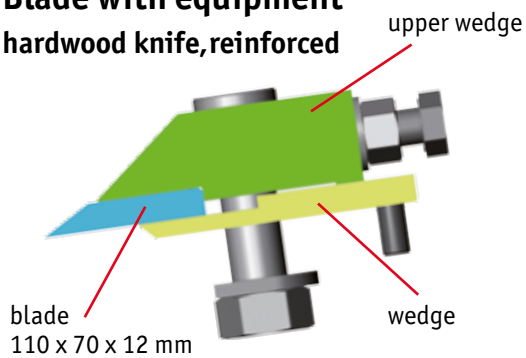

Blades

Universal blade

good for changing materials

Softwood blade

easy-running, high throughput

Hardwood blade

long service life

Hardwood blade, reinforced

extra thick, especially stable

Matching wedge

Developed for the shredder, discovered for the chipper

Wear-out metal sheets on blower housing



Not only our established Hardox wear-out metal sheets are available for almost all machine types, but also the new generation – armored wear-out metal sheets –. In this case, the lining material is further protected against wear by a special “armoring”.

Benefits:

- considerably longer service life
- therefore less machine downtime
- less machine operator servicing time

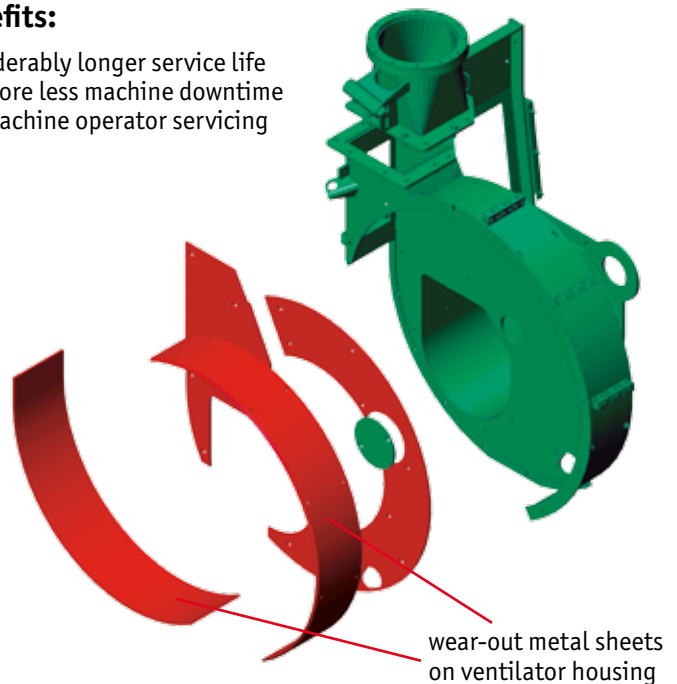

Wear-out metal sheets on discharge tube

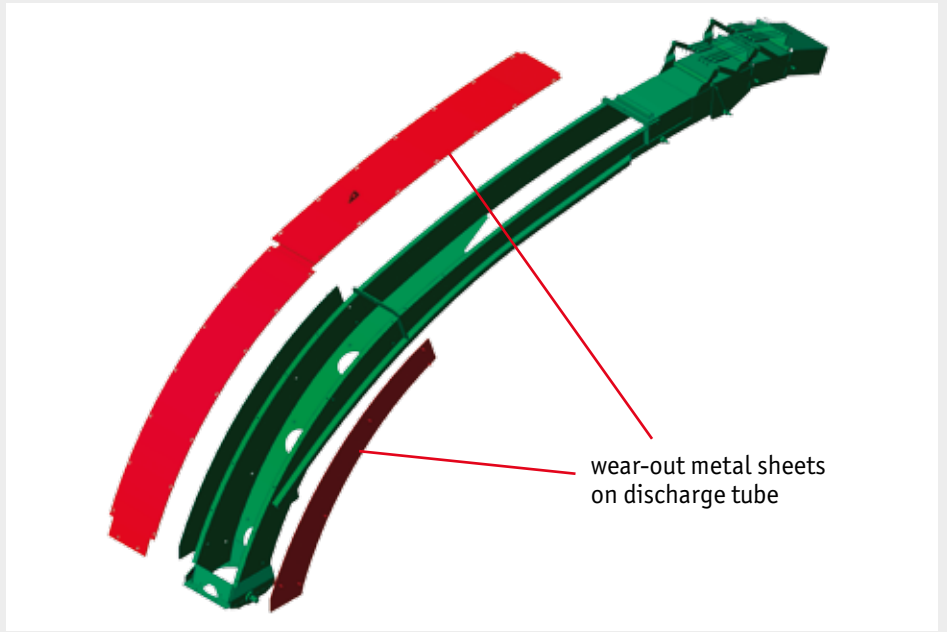
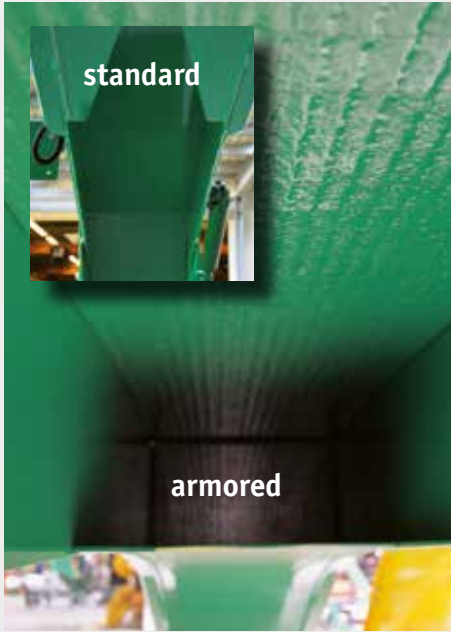

Blower wing



Wear-out metal sheets on blower wing

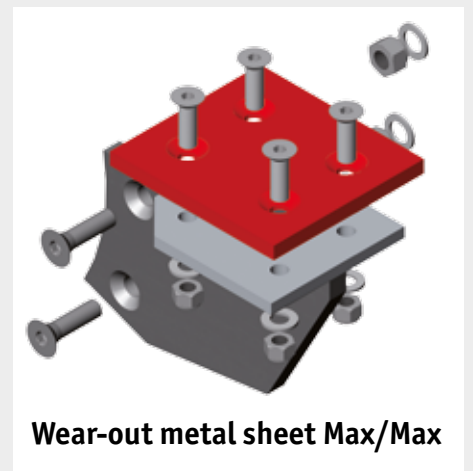
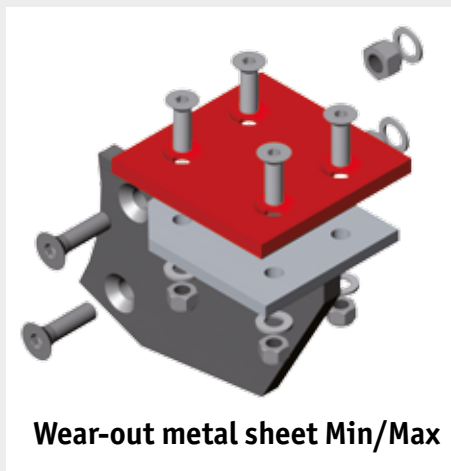
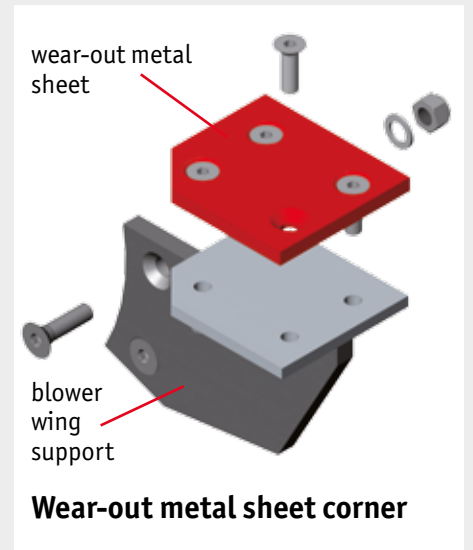

All versions available in established Hardox quality or armored

Chipper drums

Closed

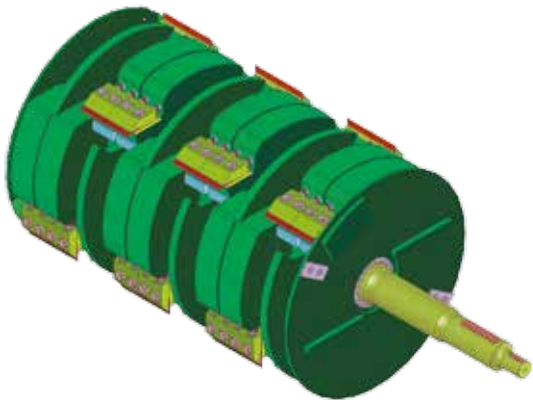

Benefits:

- less overlength with light cuttings



G100 woodchippings

Very fine chippings
for pellet production



Open

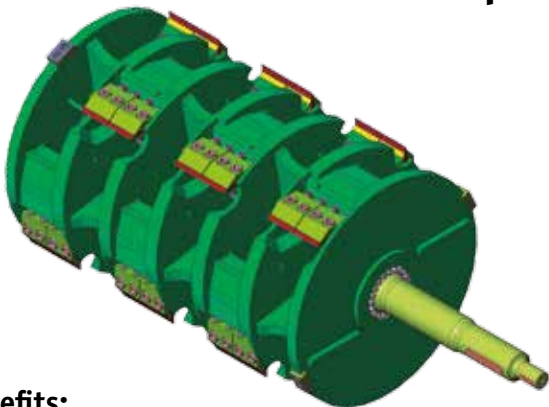

Benefits:

- less fines content and good chipping flow with coarse chippings

brief facts

All drums can be fitted with any number of blades (depending on the material to be chipped). When operating the rotor with twelve blades the "empty" blade spaces can be identified by their drill holes.*

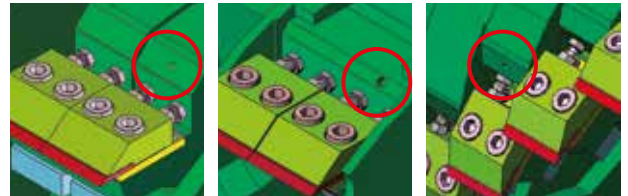

Helix

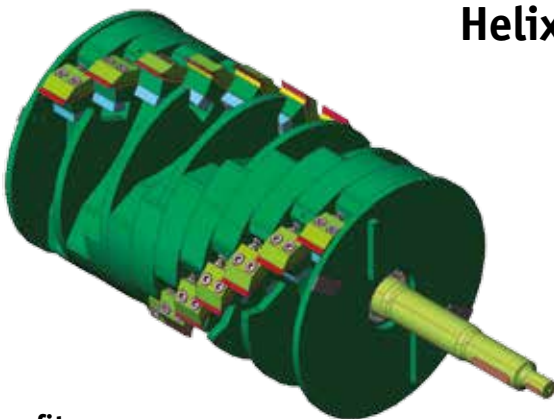

Benefits:

- extremely quiet, jerk-free running when chipping standing timber and fine woodchippings

H1

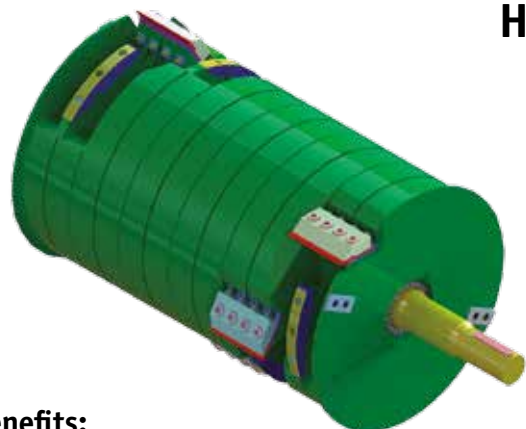

Benefits:

- coarse woodchippings with very low fines content
- optimised woodchipping flow
- rapid adjustment of pre-grip using wedges

Product service

Accessibility:

Mon. – Thu.: 7.00 – 17.30

Friday: 7.00 – 16.30

Saturday: 7.00 – 12.15

On Saturdays, goods issue is only possible by prior arrangement.

E-mail queries:

Service: service@jenz.de

Warranty cases: garantie@jenz.de

Spare parts orders: parts@jenz.de

Important phone numbers:

**Service hotline
national & international**

+49 (0) 5704/9409-20 or 30

Spare parts orders:

+49 (0) 5704/9409-21 or 16



JENZ GmbH

Maschinen- und Fahrzeugbau

Wegholmer Str. 14 | D-32469 Petershagen

Phone: +49 (0) 5704/9409-0

Fax: +49 (0) 5704/9409-47

E-Mail: info@jenz.de

