

**TRY BEFORE  
YOU BUY**

**TESTING LAB**



- Choose the most suitable equipment.
- Test your own material.
- Touch the result with your own hands.

# SINCRO 215 eko

## COMPACT GRANULATOR

The compact granulator model **SINCRO 215 eko** is designed to process rigid and flexible cables. With shredding and subsequent dry separation we are able to efficiently separate copper and aluminum from the insulation (plastic, rubber or paper). The unit can be fed manually or automatically with the addition of a conveyor depending on user's specific requirements.

Production up to 65 kg/h input material, variable depending on the material being processed.

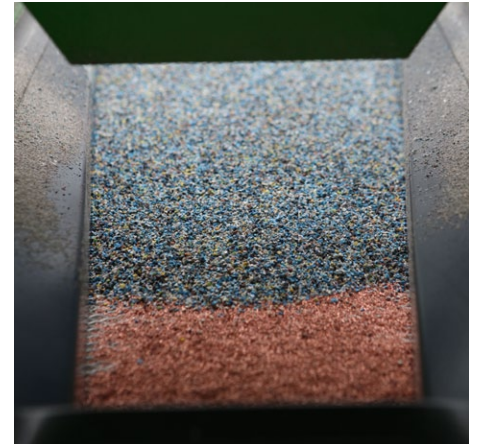

Cutting chamber

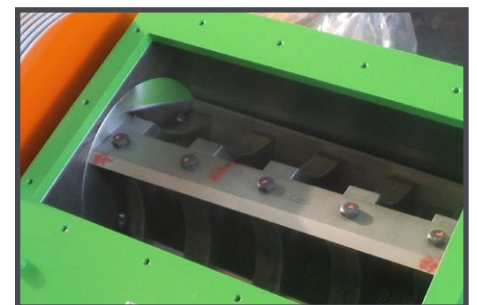

Easy maintenance



Manufactured in accordance to CE rules

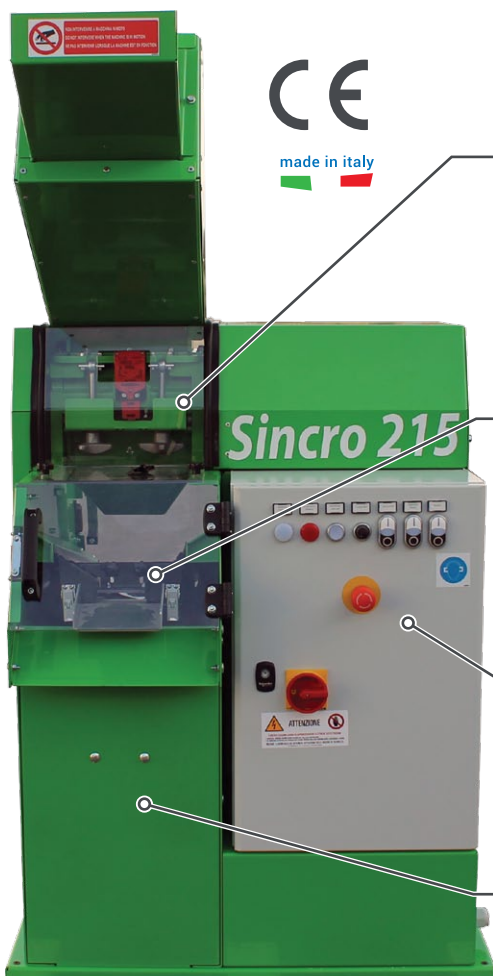

CE

made in Italy

**Granulator knives**

are manufactured and adjustable to obtain the highest cutting efficiency mounted inside a self cooling cutting chamber.

**Dry separation table**

that is adjustable and easy to access for cleaning and maintenance.

**Operator controls**

simple and easy to use.

**Two air fans**

used to obtain maximum separation with simple adjustment.

## EXAMPLES OF INPUT MATERIALS



## EXAMPLES OF OUTPUT MATERIALS



## TECHNICAL SPECIFICATIONS

- Feeding: **Automatic or Manual**
- Rotor diameter: **170 mm**
- Number of rotating blades: **3**
- Number of fixed blades: **2**
- Screen sizes: **Ø 2-3-4-5-6 mm**
- Drive type: **V- belts**
- Installed power: **3,6 kW - 7,2 A**
- Voltage (standard): **400 V - 50 Hz**
- Separation tables: **60µ up to 200µ screen**
- Total weight: **360 kg**
- Noise level (as per sample test): **82 db(A)**

## PRODUCTION RATES

Input production rates are dependent on material input type and size. Products shredded prior to input will increase production rates.

## INPUT MATERIAL CAPABILITIES OF UNSHREDDED CABLE

- Flexible copper cable up to: **Ø12-15 mm**
- Rigid copper cable up to: **Ø10-13 mm**
- Aluminium cable up to: **Ø12-15 mm**

## OPTIONALS

- Rotary valve.  
(To ensure even feeding)
- Powder feed system.  
(For oily, sticky adhesive materials powder dosing system)
- Dust collection.
- Extended warranty.

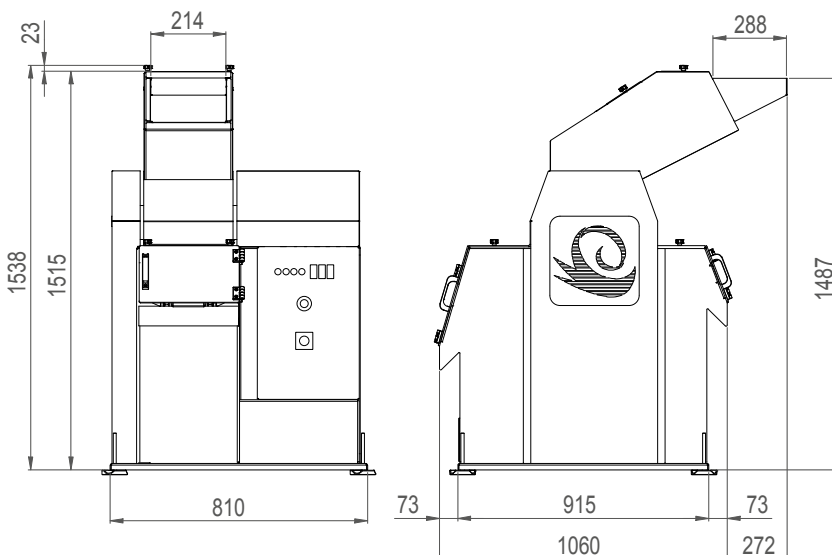

PRODUCTION COMPARATIVE GRAPHIC FOR MACHINE RANGE

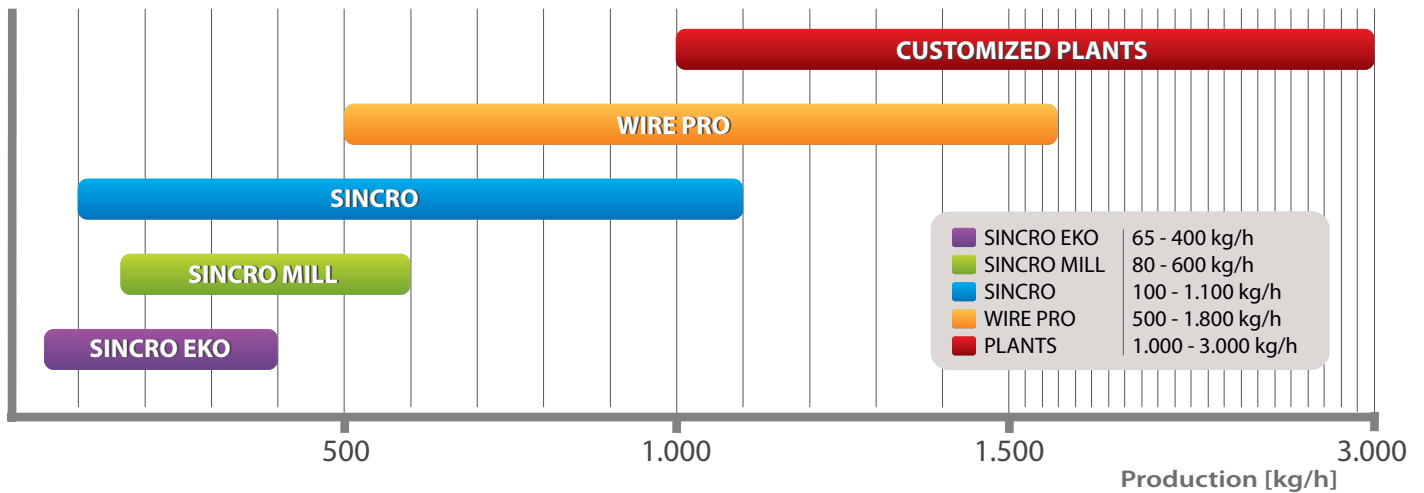

WHY CHOOSE SINCRO 215 EKO

- Best price/quality ratio.
- Rapid return of the investment.
- High resale value maintained over time.
- Compact, the perfect solution for small space.
- Ecological with low energy consumption and low noise level.
- Wide range of material that can be recycled.
- Easy to use and maintain.
- Fast and reliable service by factory trained technicians.

COMBINATIONS

All Sincro granulators can be combined to other Guidetti products to increase the production and quality:

- Conveyor belt.  
(For the feeding of machines or to collect separated materials)
- Circular vibrating sieve.  
(To recover metal dust)
- Magnetic separator.



WARRANTY EXTENTION

"YOU WORK WE CARE"

Warranty extensions can be purchased for up to 24-36 months from date of shipment. Extended warranty covers the replacement of parts that are defective. Wear items are excluded from all warranties. A yearly visit by a factory trained technician (2 or 3 depending on the extension purchased) will be made to verify the general condition of the equipment.



GUIDETTI SRL  
Via Salvi, 1  
44045 Renazzo (FE), ITALIA  
Piva: 01460390386  
Tel: +39 051 6858511  
info@guidettisrl.com

guidettisrl.com



GUIDETTI USA LLC  
180 Enterprise Boulevard SW  
Atlanta GA 30336, U.S.A.  
Ph. +1 770 9548780  
info@guidettiusa.com

guidettiusa.com