

**TRY BEFORE  
YOU BUY**

**TESTING LAB**



- Choose the most suitable equipment.
- Test your own material.
- Touch the result with your own hands.

# WIRE PRO 1000

## COMPACT RECYCLING PLANT

The **WIRE PRO 1000** is a refining machine designed to process and recover copper and aluminum from the recycling of different materials (mainly cables or radiators). Very Environmentally Friendly, with excellent dust suppression systems, no pollutants are released into the atmosphere, fully soundproofed for the lowest sound levels in the industry, this coupled with lowest energy consumption and highest cutting efficiency. The continuous running and the compact size make **WIRE PRO 1000** particularly suitable for its insertion in recycling plants.

Production from 400 kg/h up to 500 kg/h input material, variable depending on the material being processed.



### EXAMPLES OF USE

- Recovery of metals from electric cables (separation between copper and aluminum, separation of copper or aluminum from the insulating material);
- Recovery of metals from radiators (separation of copper, aluminum, etc.).

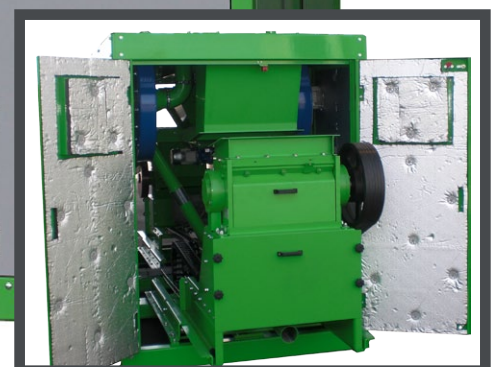
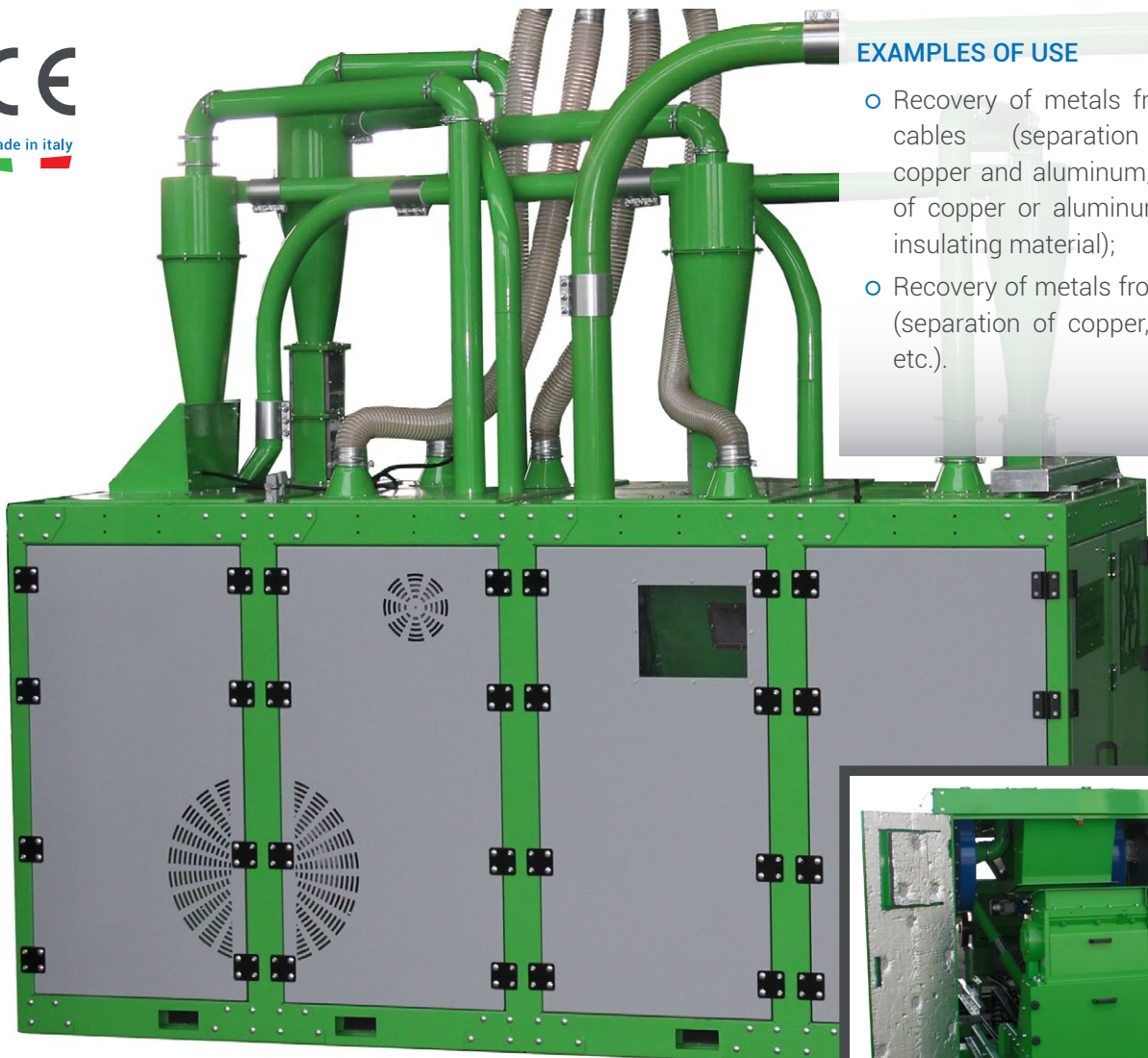

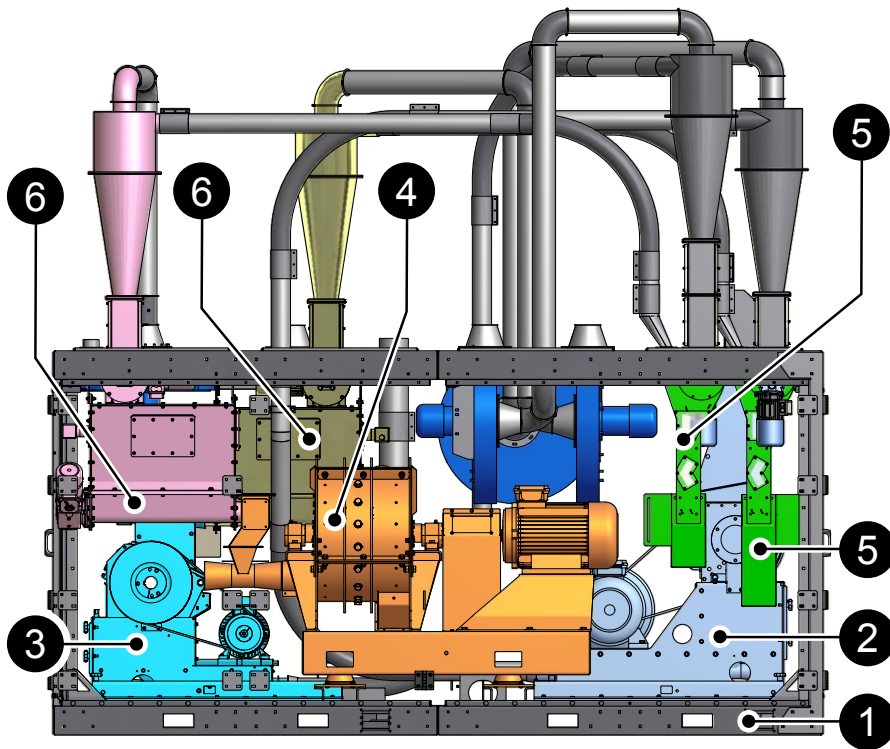

### MAIN COMPONENTS

- 1 Base  
made of 8 mm thick bent sheet metal
- 2 High-speed blade pre-shredder (Rasper)  
mod. Rasper 400
- 3 Granulator or Blade Mill  
mod. G415
- 4 Refiner  
mod. Turbo 625/2
- 5 Zig-Zag Separator  
mod. ZZ200
- 6 Auger dosing unit

### DIMENSIONS INPUT/OUTPUT

- A Input feeding: 420 x 325 mm
- B Outlet opening: Ø 50 mm

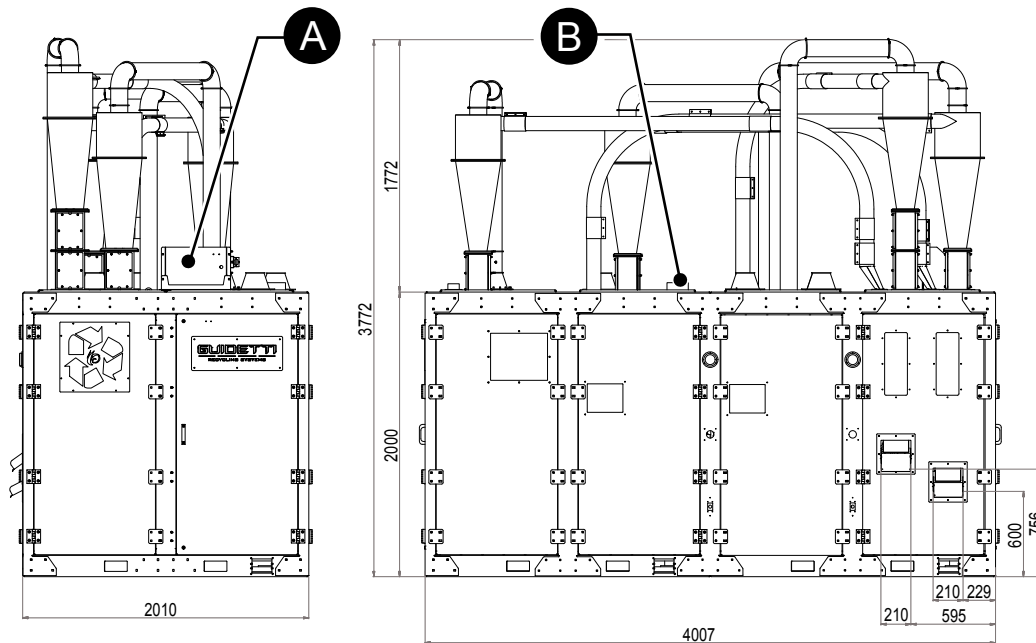

### TECHNICAL SPECIFICATIONS

- Feeding: **Automatic**
- Available screen sizes (Rasper): Ø 10-12-15 mm
- Available screen sizes (Granulator): Ø 4-5-6 mm
- Installed power: **78 kW - 150 A**
- Voltage (standard): **400 V - 50 Hz**
- Total weight: **5600 kg**
- Noise level (as per sample test): **85 db(A)**

### OPTIONALS

- Powder feed system.  
(For oily, sticky adhesive materials powder dosing system)
- Conveyors to collect output material.
- Magnetic separator.
- Dust collection.
- Extended warranty.



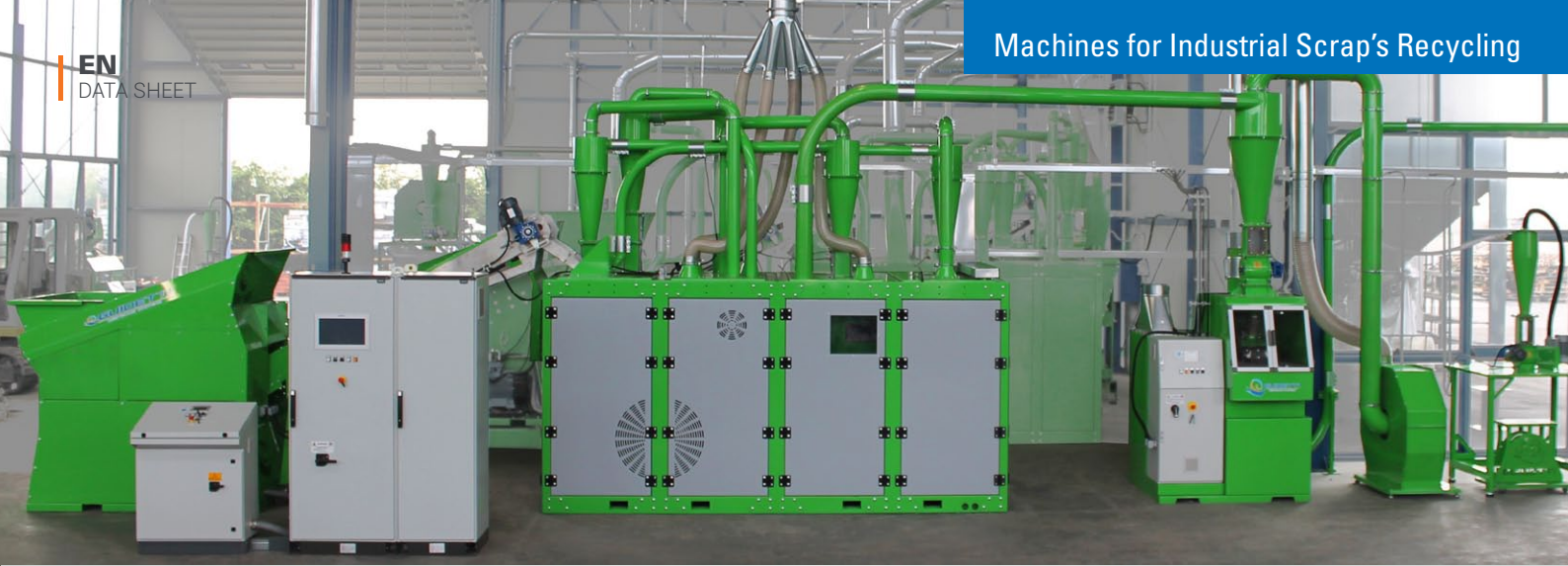

## WIRE PRO 1000 LINE

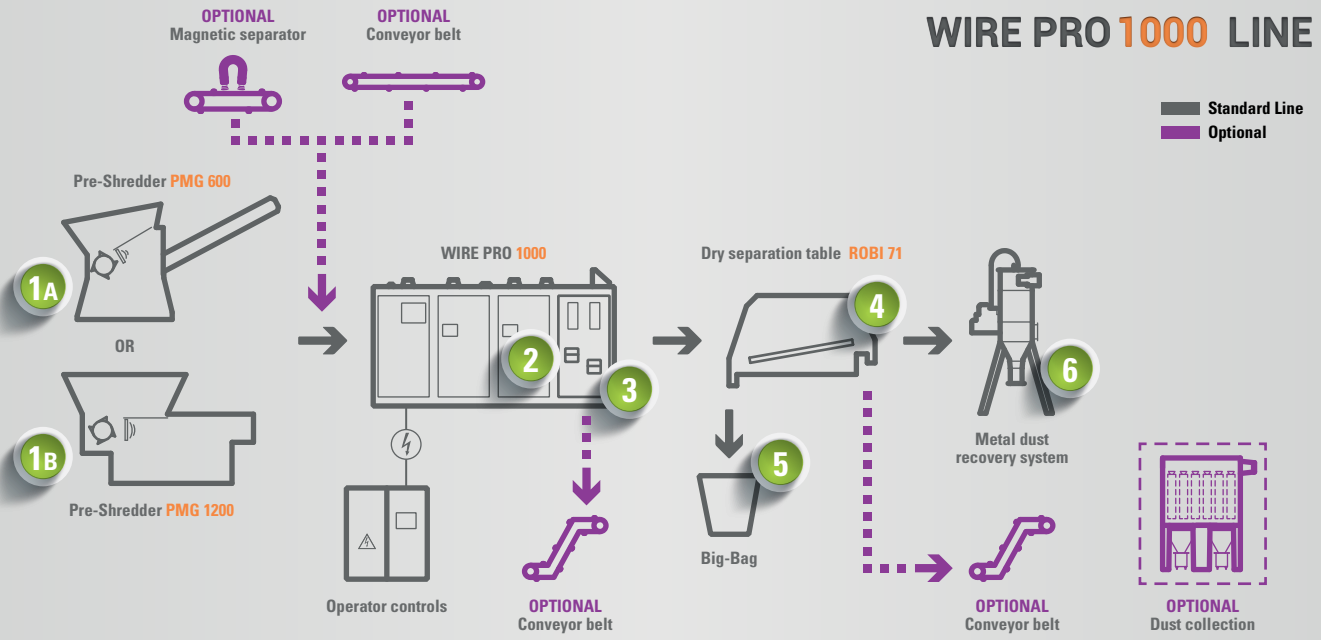



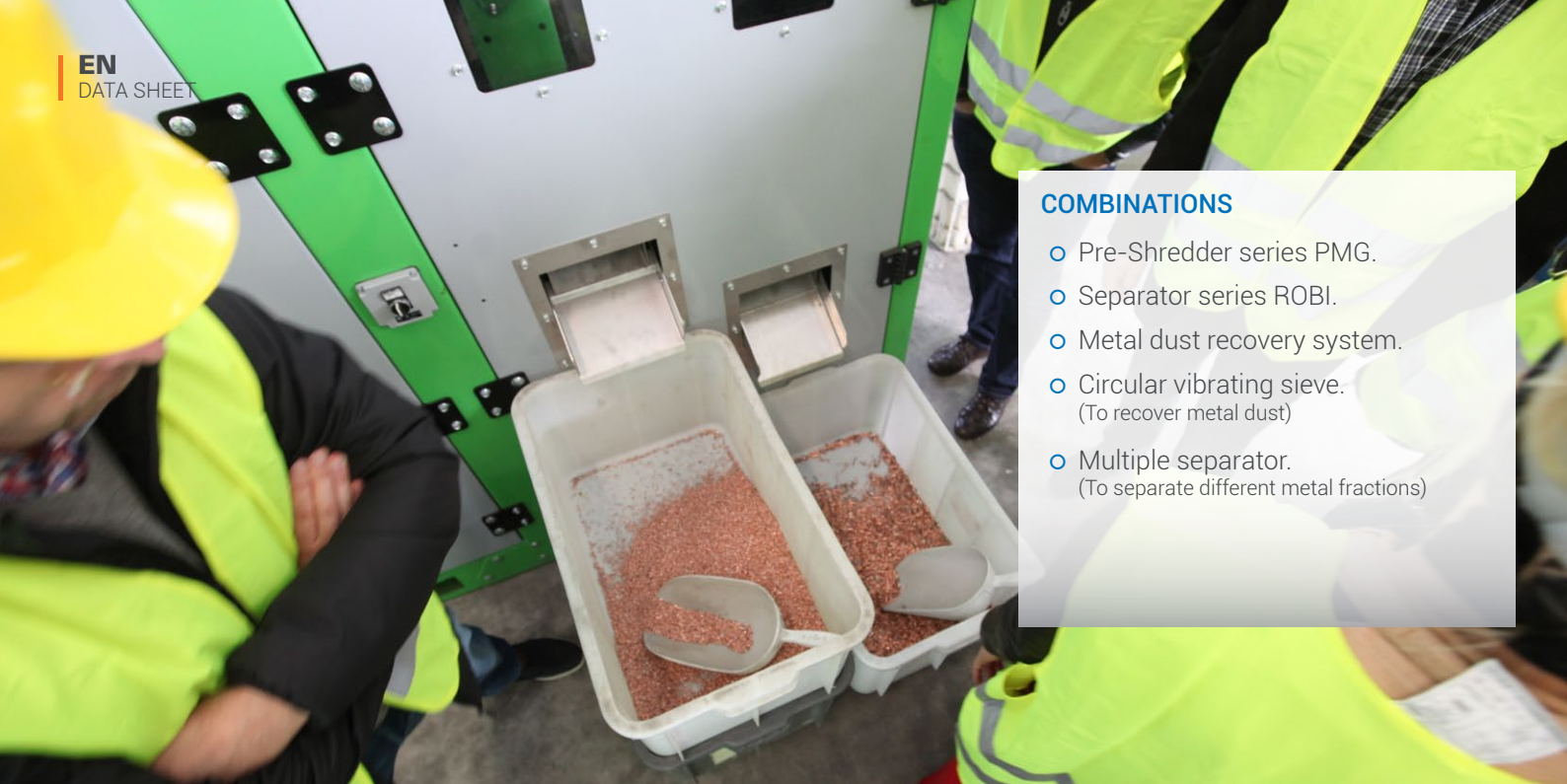

### COMBINATIONS

- Pre-Shredder series PMG.
- Separator series ROBI.
- Metal dust recovery system.
- Circular vibrating sieve.  
(To recover metal dust)
- Multiple separator.  
(To separate different metal fractions)

### PRODUCTION COMPARATIVE GRAPHIC FOR MACHINE RANGE

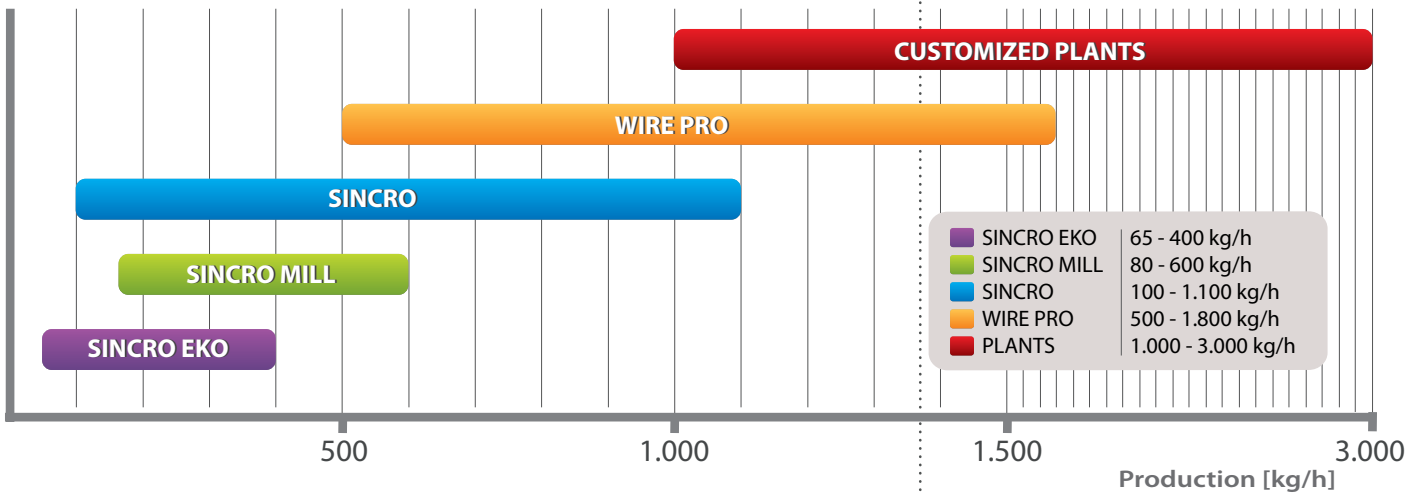

### WARRANTY EXTENTION

"YOU WORK WE CARE"

Warranty extensions can be purchased for up to 24-36 months from date of shipment. Extended warranty covers the replacement of parts that are defective. Wear items are excluded from all warranties. A yearly visit by a factory trained technician (2 or 3 depending on the extension purchased) will be made to verify the general condition of the equipment.

**CUSTOMER CARE**  
**+39 051 68.58.513**  
 service@guidettisrl.com



GUIDETTI SRL  
 Via Salvi, 1  
 44045 Renazzo (FE), ITALIA  
 Piva: 01460390386  
 Tel: +39 051 6858511  
 info@guidettisrl.com

guidettisrl.com



GUIDETTI USA LLC  
 180 Enterprise Boulevard SW  
 Atlanta GA 30336, U.S.A.  
 Ph. +1 770 9548780  
 info@guidettiusa.com

guidettiusa.com