

UNTHA

The reliable brand!



The pioneer when it comes to the single-pass shredding of waste

XRC CLASS

Single-shaft shredder for efficient coarse, medium and fine shredding of different material flows



Table of contents

XR stationary	3
XR mobil-e	9
XR System solution	13
XR Top benefits	16
XR Technical data	20

XR Class built to perform

Maximum productivity

Highest possible performance and flexibility and even greater reliability when it comes to shredding different materials: these are the benefits we have achieved through our ongoing development of the XR class. Thanks to numerous innovative features, the unit is now even more adaptable to specific customer requirements.







For more information on performance, see here:



The highlights

- » **Maximum performance:** High throughput rate and maximum availability
- » **Powerful shredding:** Issue-free shredding even of difficult materials
- » **Highly versatile:** A single machine for different material flows
- » **Low energy cost:** Tangible savings thanks to UNTHA Eco Power Drive
- » **Efficient maintenance:** Minimal downtime thanks to low-maintenance components
- » **Suitable for mobile use:** Maximum flexibility on your premises

Suitable for:

-  Commercial and industrial waste
-  Domestic waste
-  Bulky waste
-  Waste wood
-  Pulper ropes
-  Metal
-  Plastic bales



XR stationary

Your benefits at a glance

Energy-saving UNTHA Eco Power Drive

Drive system with energy efficient UNTHA Eco Power Drive ensures unprecedentedly low energy use at higher performance compared to standard drive types. The wear-free direct drive reduces maintenance costs as belts or shaft stubs are not required. The load-dependent speed control ensures a high throughput rate.



Ergonomic maintenance

Thanks to the carefully considered machine design, operators are able to work comfortably, speedily and safely and in an upright position.



Defined fraction size

Screening bars or a perforated screen ensure a homogeneous, defined fraction size.

Robust steel frame construction

Warp-resistant, solid profile tubes are ideal for tough operating conditions and low-vibration operation. Thanks to its compact design, the unit is easy to integrate into existing plants. The low filling level enables loading with a wheel loader.

Robust feed hopper

3-sided hopper for loading with a wheel loader or 4-sided hopper for higher filling volumes and loading with material handlers or conveyors.

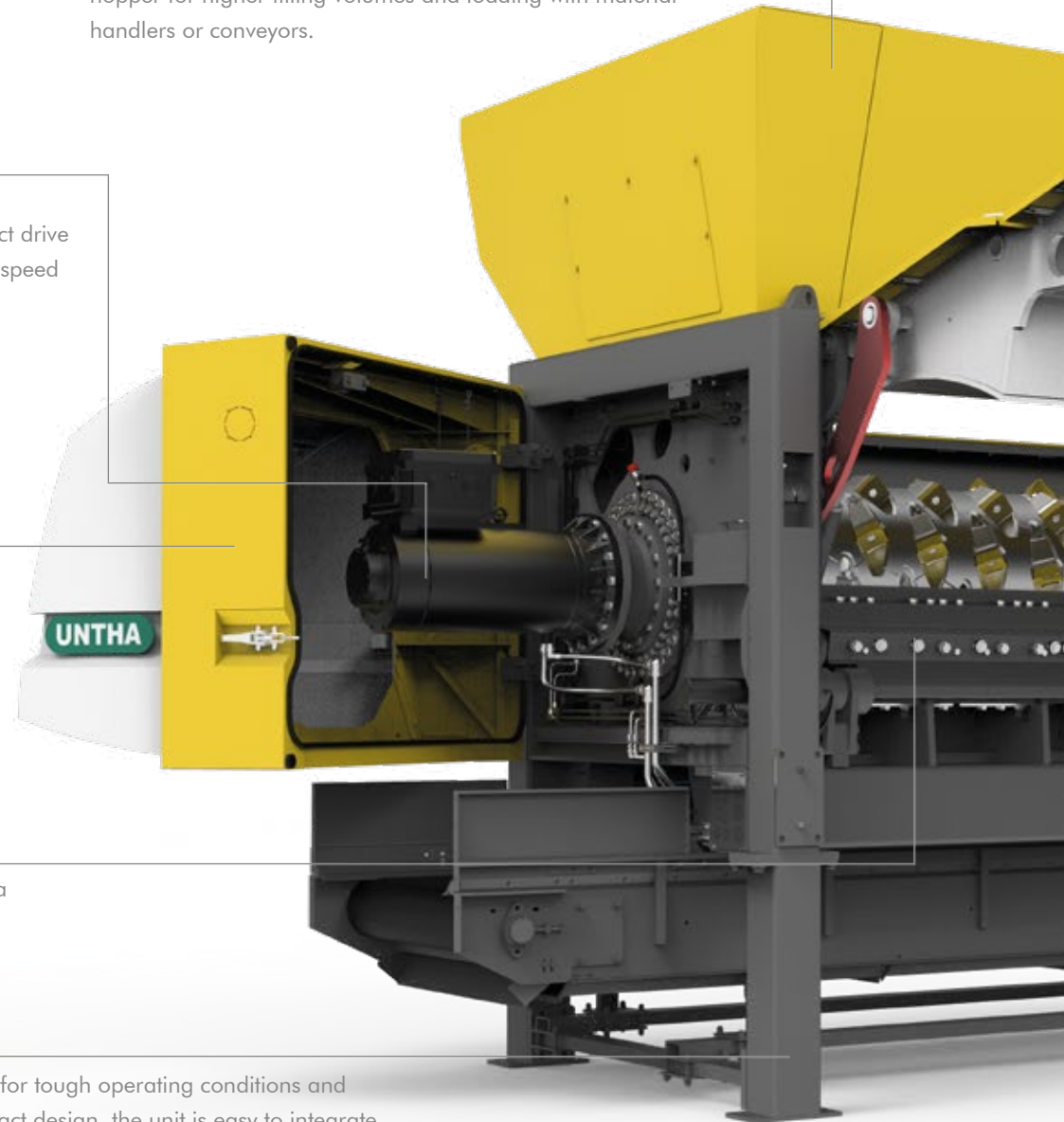

Sample image XR3000

Effective cutting systems

RC, C and XC cutting system for different requirements and materials. All cutters and stator blades are reusable and easy to exchange.

Internal pusher system

Ensures continuous material intake, in particular when processing bulky materials.



Automatic central lubrication

Makes for longer maintenance intervals and reduces servicing requirements.

Efficient discharge system for extraneous matter

Enables the speedy removal of extraneous matter from the cutting chamber.

Adjustable cutting bars

The cutting gap can be adjusted from the outside without opening the maintenance flap.



High level of user-friendliness

Machine is operated via a 7" colour touch display.

Options

Extras

- » **Safety coupling:** Protects the cutting system and the power train by means of a precise torque limit at higher speeds
- » **Quick-change screen system:** Straight-forward, time-efficient change of the screen by a single person
- » **Hard surfacing of the rotor:** Significantly increases rotor availability with abrasive materials
- » **Radio remote control:** Hassle free machine operation from different locations
- » **Waste wood package:** Ensures the optimal processing of waste wood

Services

- » **UNTHA GENIUS:** A condition monitoring tool which helps monitor, measure and optimise shredder productivity, in real-time, from an operator's smartphone, tablet or PC – irrespective of location.
- » **UNTHA Carefree Packages (Basic, Standard, Professional):** Ensure that machines are technically sound and ready for use at all times.

For more information on structure and functionalities, see here:



The right cutting system for any requirement

Depending on the material and fraction size, several cutting systems with different blade shapes are available with the RC, C and XC system. The cutting systems allow fraction sizes from 25 to 300 mm. Depending on the material and the diameter of the perforated screen, the throughput rate varies between

10 t/h and 70 t/h. The cutters are reached through the maintenance flap and may be loosened easily via a screw connection. Extraneous matter may be removed easily and quickly through the dedicated exit door. The cutting gap for all cutting systems may be adjusted from the outside, ensuring a perfect

shredding result. The optional hard surfacing of the rotor significantly increases the lifespan of the rotors with abrasive materials.

Reliable pre-shredding

RC cutting system

The RC cutting system was specifically developed for the coarse pre-shredding of different material flows and for high throughput rates of up to 70 t/h. The purpose-built shape of the blades ensures a particularly aggressive intake behaviour for the material. The cutters and the stator bar may be welded on again at the end of the service life.

Materials:

- » Commercial and industrial waste
- » Domestic waste
- » Bulky waste
- » Waste wood and pallets
- » Production waste
- » Plastic bales
- » and much more

Obtainable fraction sizes [mm]:

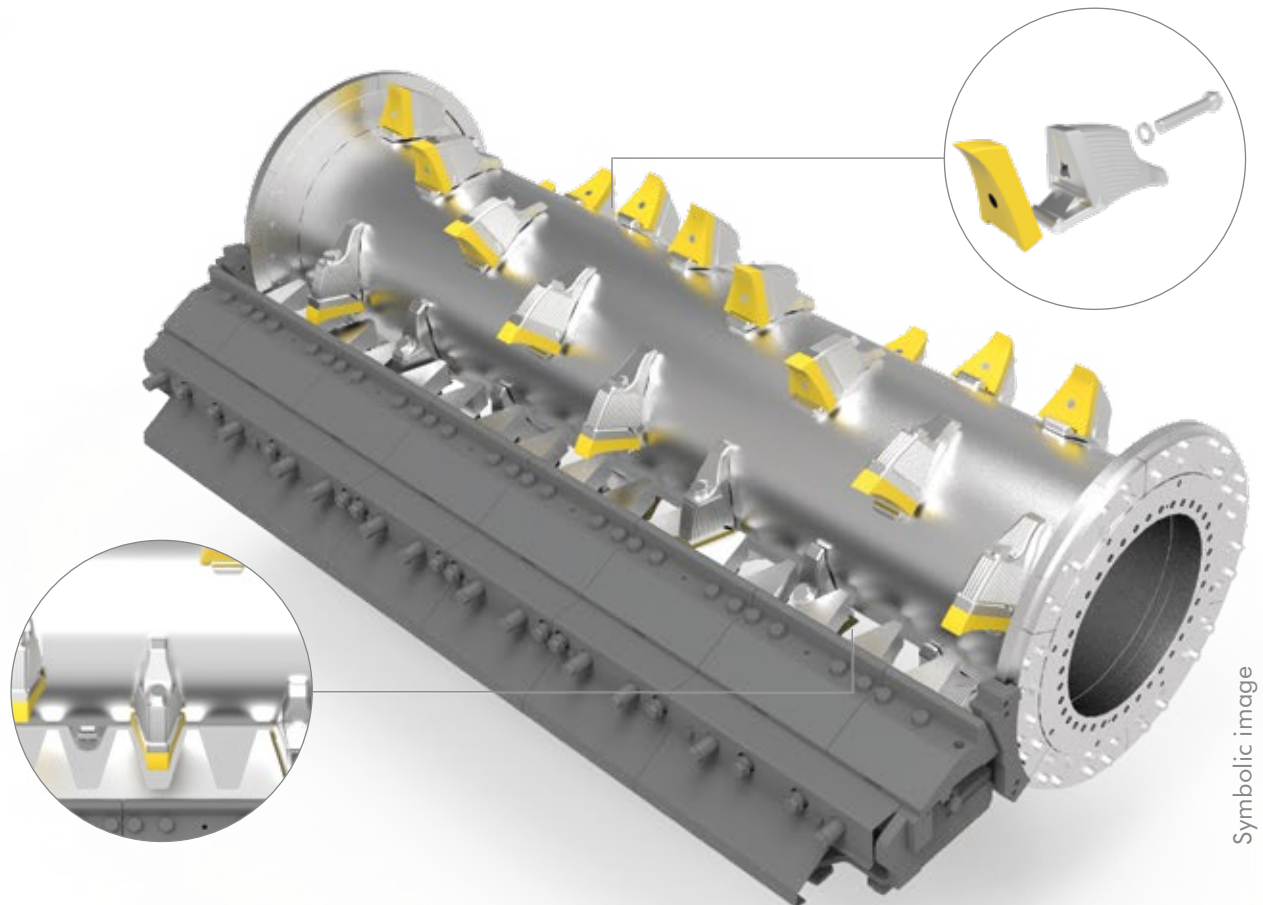
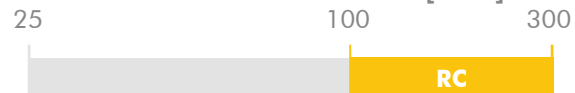

Efficient medium shredding

C cutting system

The C cutting system was developed for the single-pass shredding of different material flows to a defined fraction size. Depending on the requirements and the diameter of the perforated screen, up to four rows of blades on the rotor ensure high throughput rates. The indexable inserts and stator bars may be used in four different ways and are easy and quick to replace.

Materials:

- » Commercial and industrial waste
- » Domestic waste
- » Bulky waste
- » Waste wood and pallets
- » Pulper ropes
- » Production waste
- » Plastic bales
- » Scrap aluminium
- » Sheet metals
- » Aluminium/PVC window profiles
- » Cables
- » Electronic waste
- » Mechanic-biological waste
- » Tyres
- » and much more

Obtainable fraction sizes [mm]:

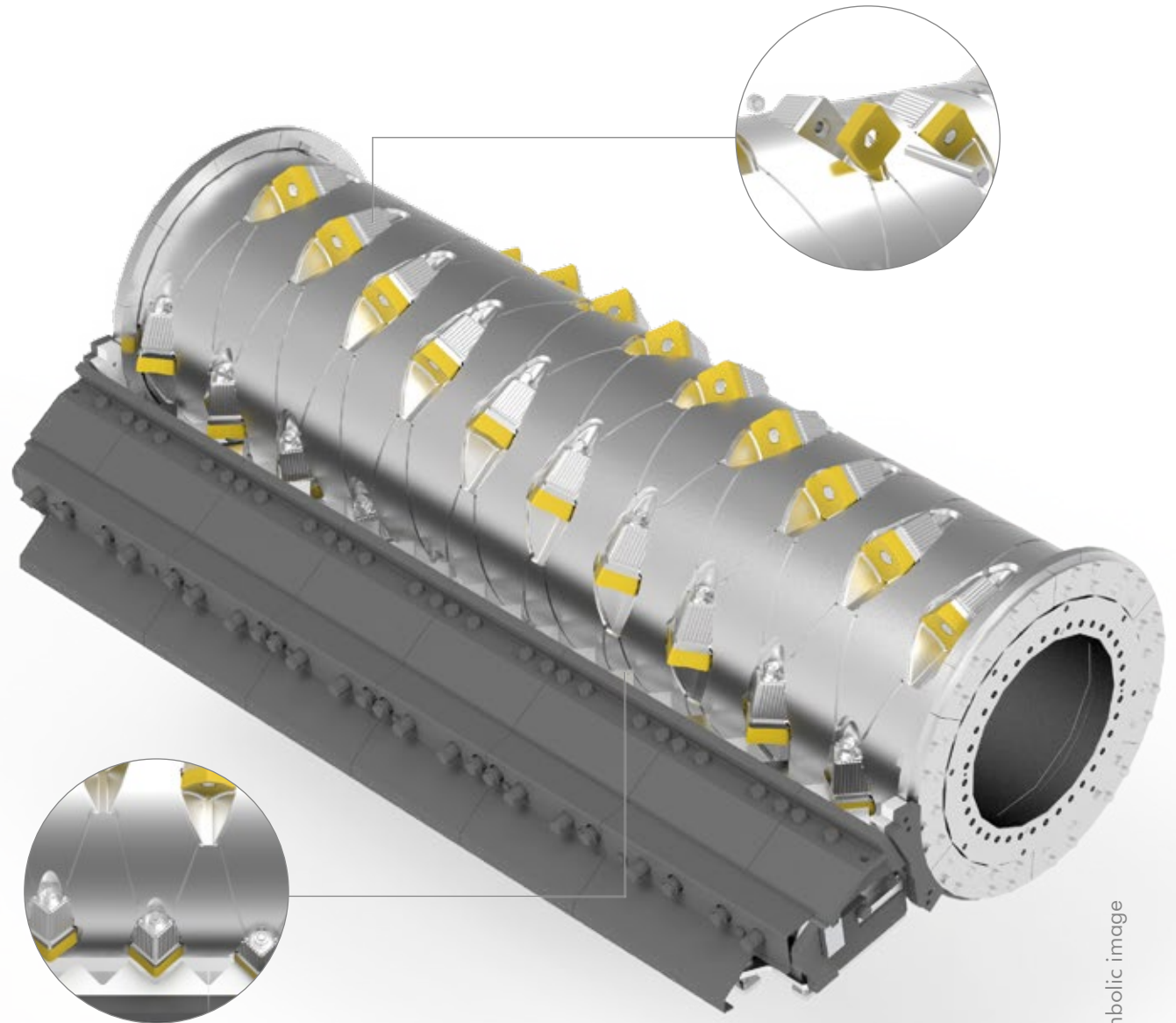

Perfect post-shredding

XC cutting system

The XC cutting system was designed for processing pre-treated or Fe-separated materials that are destined for material or thermal recovery. The strip cutters and stator bars may be used in four different ways and are easy and quick to exchange.

Materials:

- » Pre-treated or Fe-separated material flows of all kinds

Obtainable fraction sizes [mm]:

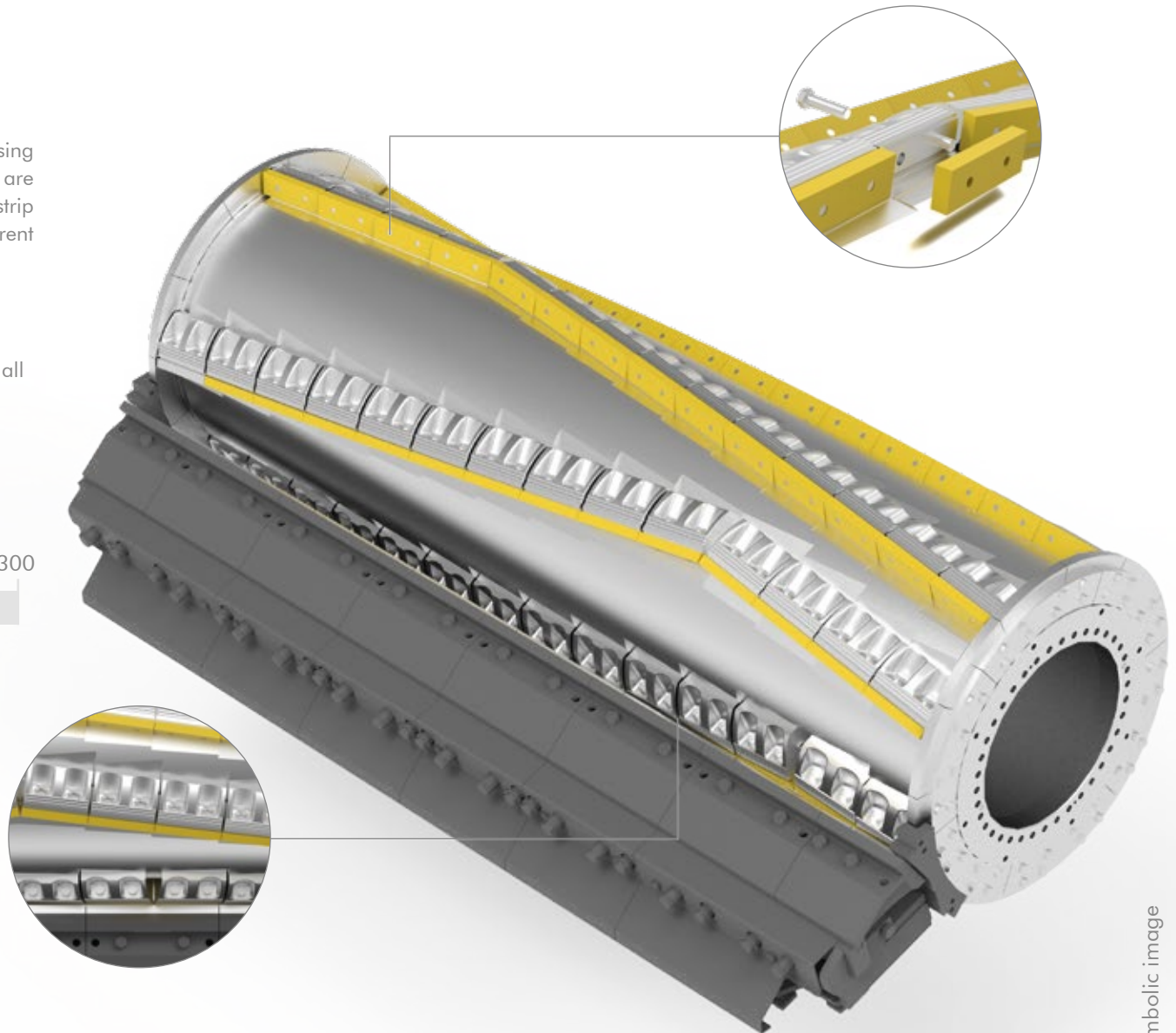

Symbolic image



XR mobil-e

Your benefits at a glance

Energy saving UNTHA Eco Power Drive

Drive system with water-cooled synchronous engine ensures unprecedentedly low energy use at higher performance compared to standard drive types. The wear-free direct drive reduces maintenance costs as belts or shaft stubs are not required. The load-dependent speed control ensures a high throughput rate.



Compact petrol and hydraulic power unit

A compact, energy efficient petrol engine produces the required energy for the crawler-type undercarriage by means of a generator.



Highly user- and maintenance-friendly

Machine is operated via a 7" colour touch display. Thanks to the thought-out machine design, operators are able to work comfortably, speedily and safely and in an upright position.



Quick-lock power plug

The machine may be connected easily and safely to the external power supply.



Height-adjustable material conveyor belt

A high-performance conveyor belt ensures the smooth removal of material. The discharge height may be adjusted easily via the operating terminal.

Effective water-cooling system

Protects drive motors, frequency converters, hydraulic systems and control cabinets against overheating.



Tried-and-tested magnetic separator

A permanent overbelt magnet reliably separates iron-containing materials from the material flow.



Reliable crawler-type undercarriage

A crawler-type undercarriage ensures that the shredder may be positioned at any location by means of a user-friendly radio control unit.

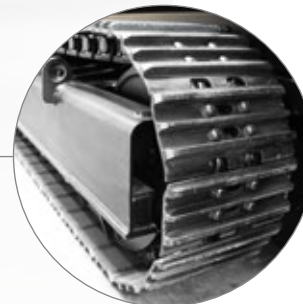

Options

Extras

- » Fire protection system to prevent fires from spreading
- » Additional flame detector for the feed hopper
- » Crawler-type undercarriage with rubber coating

Services

- » **UNTHA GENIUS:** A condition monitoring tool which helps monitor, measure and optimise shredder productivity, in real-time, from an operator's smartphone, tablet or PC – irrespective of location.
- » **UNTHA Carefree Packages (Basic, Standard, Professional):** Ensure that machines are technically sound and ready for use at all times.

For more information on structure and functionalities, see here:





Electro-mechanical drive and yet fully mobile

Like all the XR products, the XR3000 mobil-e also comes with the energy efficient UNTHA Eco Power Drive. You can rest assured that your operating costs will be minimised and your throughput and material quality maximised. The highlight: As opposed to conventional diesel-operated, energy-consuming, environmentally damaging, noisy and high-maintenance mobile units, the XR3000 mobil-e has a cost-effective, electric drive.

The combination of a crawler-type undercarriage and a small petrol engine ensures optimal mobility. Using a radio control unit, the XR3000 mobil-e may be manoeuvred to any location and is then re-connected to the power supply using a quick-lock power plug. A height-adjustable material conveyor belt and an optional magnetic separator provide everything you need for the efficient operation of a mobile shredding system.

Your benefits at a glance:

- » Up to 75% lower energy costs compared to diesel-operated mobile units
- » No exhaust emissions
- » Single-pass shredding solution for a homogeneous, defined fraction size
- » Flexibility in choosing a location for the unit on your premises
- » Low noise level
- » Low operating and maintenance costs
- » Remote maintenance
- » State-of-the-art, sustainable machine concept



XR System

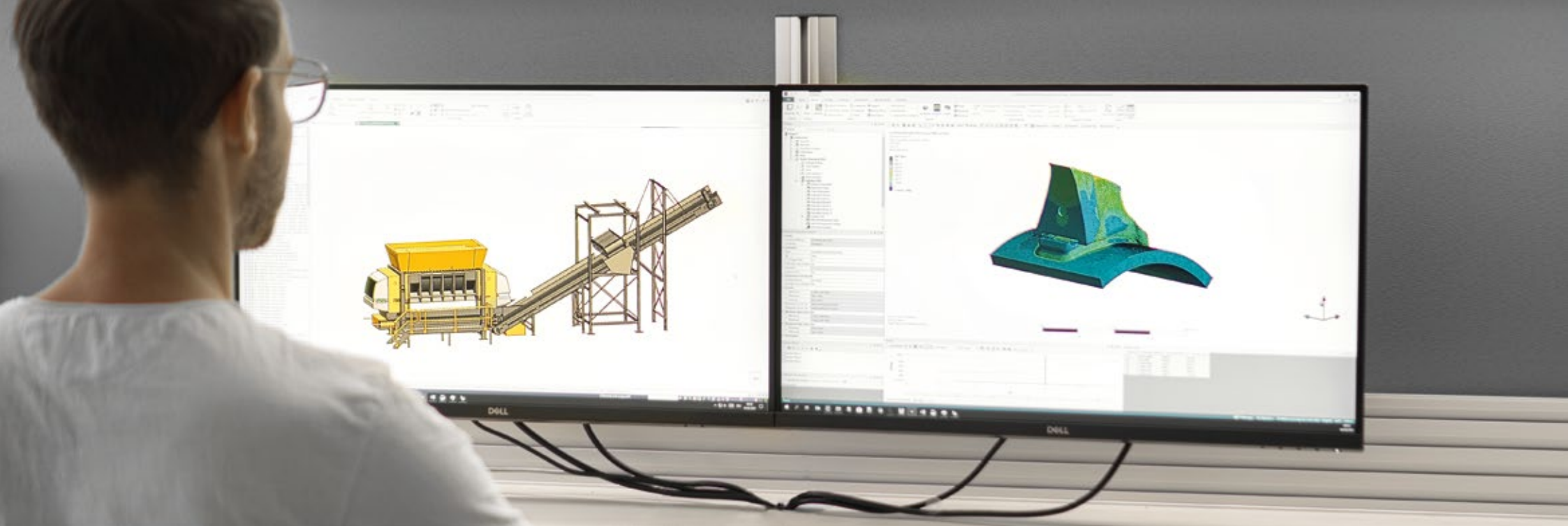

Complete turnkey solutions from a single source

UNTHA shredding technology offers complete turnkey solutions for single-pass shredding. Low investment, compact design and low operating and maintenance costs make this solution particularly attractive. It is also extremely versatile and can be used for the processing of industrial and commercial waste as well as metals, pulper ropes, bulky waste or waste wood, delivering particle sizes of 25 to 300 mm in a single shredding phase.

High-quality individual components that are perfectly coordinated ensure maximum availability of the overall system. The individual components and the shredder are easy and comfortable to operate via a central operating console.

Our highly competent project managers are at your disposal for reliable and efficient project completion, from the planning and project execution phase all the way to the successful commissioning of your facility.

Your benefits at a glance:

- » Speedy, hassle-free installation of the complete solution on site
- » High level of availability thanks to the use of high-grade individual components
- » Easy operation of the complete system via a centralised operating console
- » Easy integration in existing plant concepts

System solution, including components, at a glance

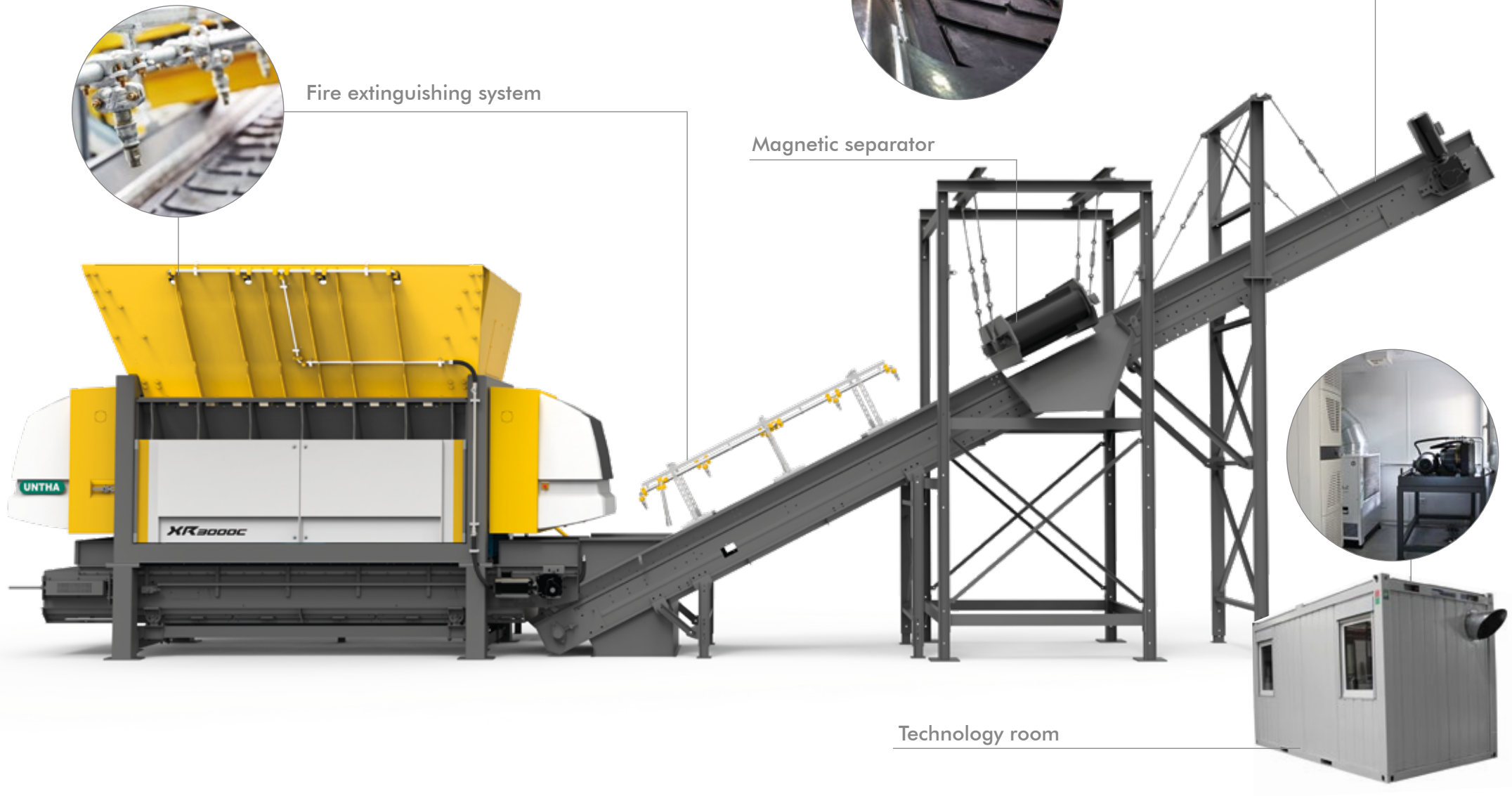

Fire extinguishing system

Magnetic separator

Discharge conveyor system

Technology room



XR Top benefits

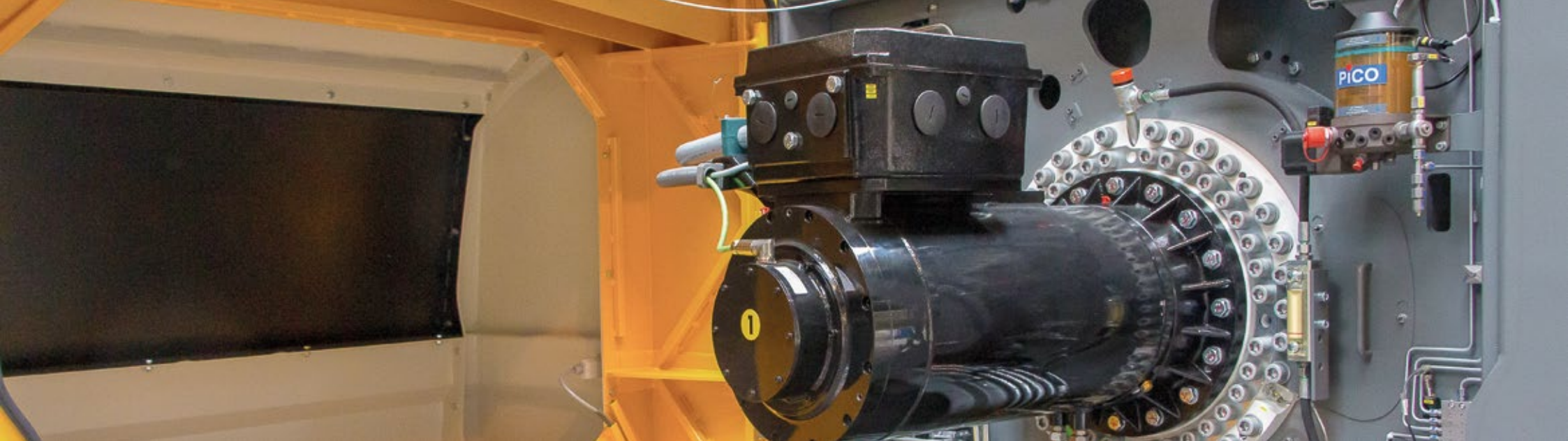

UNTHA Eco Power Drive

More performance, tough inside and out, and yet economical: that's the UNTHA Eco Power Drive in a nutshell, and that's what makes it one of the most powerful and efficient drive systems in the world.

Innovative

This highly efficient direct drive consists of high-torque synchronous motors and a planetary gear that is integrated in the rotor. No other drive concept offers this much power and throughput when it comes to shredding. In addition, the system is resistant towards extraneous matter and extremely quiet.

Powerful

Power by name, power by nature. The load-dependent speed control ensures the continuous, automatic adjustment of torque and speed, ensuring

high throughput rates for a wide range of different materials.

Economical

The high efficiency level of the water-cooled drive motors translates into tangible savings: with the UNTHA Eco Power Drive, energy costs are up to 75% lower than with conventional hydraulic drive concepts. The wear-free direct drive reduces maintenance costs as belts or shaft stubs are not required. It goes without saying that the UNTHA Eco Power Drive fulfils the requirements of the highest energy efficiency class IE4 (Super Premium Efficiency).

Flexible

Depending on the material requirements, the drive may be designed for combination with different gear

ratios: low gear ratio for tough applications, high gear ratio for high throughput rates with light materials. As an additional protection mechanism against damage from extraneous matter, a low-maintenance safety coupling that runs in an oil bath is an option.

Your benefits at a glance:

- » High-performance direct drive for a high throughput
- » Resistant towards extraneous matter
- » High energy efficiency
- » Low energy
- » Low noise emission



UNTHA GENIUS: Your shredder's brain

Maximise the productivity of your plant

UNTHA GENIUS is an intelligent condition monitoring tool for your UNTHA shredder. With the help of reliable sensor technology, the operation of your machine is monitored on an ongoing basis. GENIUS processes all your data in real-time, alerts you of any deviations and sends decision support directly to your smartphone, tablet or PC. With UNTHA GENIUS, you always have a complete overview of your entire UNTHA machine pool.

Make the most of this information on the basis of compact real-time data to see if your production is running smoothly. The goal of UNTHA GENIUS is clear: to help you maximise the availability and performance of your machine while minimising maintenance and downtime costs. But UNTHA GENIUS is much more than a standard monitoring tool - it is also a fantastic analysis tool. Thanks to the long-term storage of process data, it is possible to uncover performance trends that can lead to the ongoing optimisation of your machine, maximum cost-effectiveness and long-term return on your

investment. UNTHA GENIUS may be used with all UNTHA industrial shredders.

UNTHA GENIUS
in a nutshell:





Reliability throughout the lifetime of your unit

UNTHA Service Competence Center

UNTHA shredders are in operation all over the world and are appreciated for their longevity and reliability. If there is an unplanned machine shutdown or unexpected challenges occur, our service experts are quick to help. With the

UNTHA Service Competence Center, we assist you throughout the entire product lifecycle and offer you comprehensive service products to maximise the availability of your machine. From regular maintenance and the provision of original

replacement and wear parts to our individual Carefree Packages - we ensure that UNTHA machines are ready for use at all times and do what they were built for: the reliable shredding of material.

XR stationary

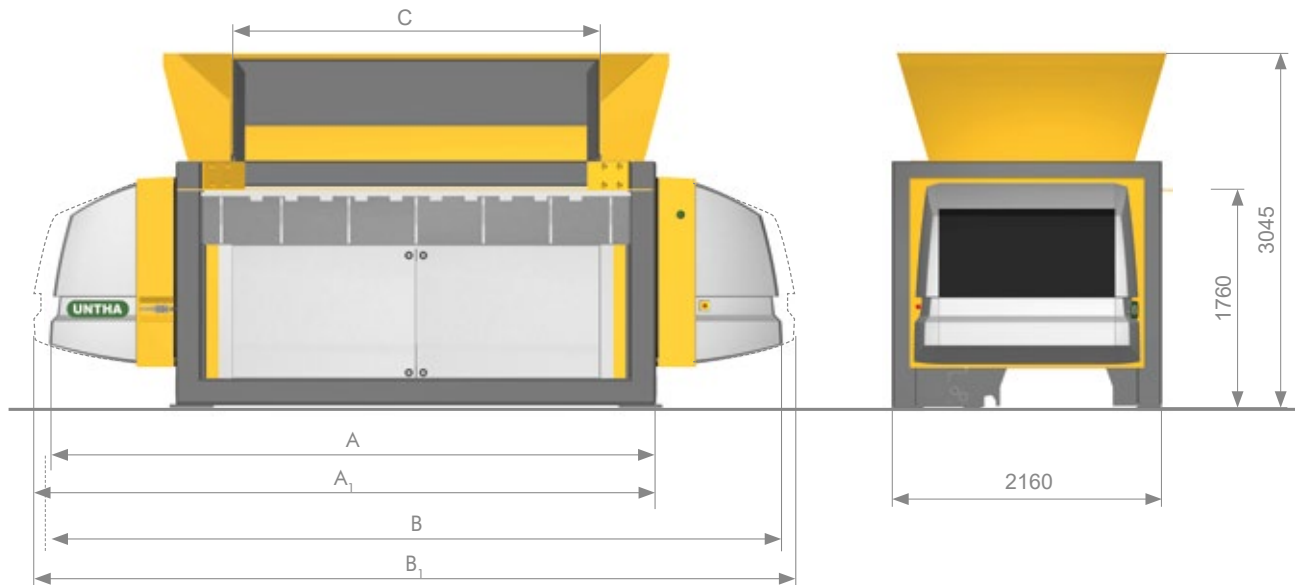

UNTHA ECO POWER DRIVE	XR2000	XR3000
A	4.070	5.070
B	5.280	6.280
C	1.980	2.960

UNTHA POWER DRIVE	XR2000	XR3000
A ₁	4.300	5.530
B ₁	5.510	6.740
C ₁	1.980	2.960

All dimensions in mm

TECHNICAL DATA			XR2000	XR3000	XR3000 mobil-e
RC	UNTHA Eco Power Drive	kW	1 x 132 2 x 132		2 x 132 2 x 160
	UNTHA Power Drive	kW	1 x 132 1 x 160 2 x 132 2 x 160		-
C	UNTHA Eco Power Drive	kW	1 x 132 2 x 132		2 x 132 2 x 160
XC	UNTHA Eco Power Drive	kW	1 x 160	1 x 160 2 x 132 2 x 160	2 x 132 2 x 160
	UNTHA Power Drive	kW	1 x 160	2 x 132 2 x 160	-
Rotor speed		U/min	max. 55 (RC) max. 85 (C) max. 103/145* (XC)		
Rotor length		mm	2.000	3.000	3.000
Rotor Ø		mm	1.000		
Weight		t	approx. 21	approx. 24	approx. 37

All dimensions in mm

* only applies if the hopper is closed

XR mobile

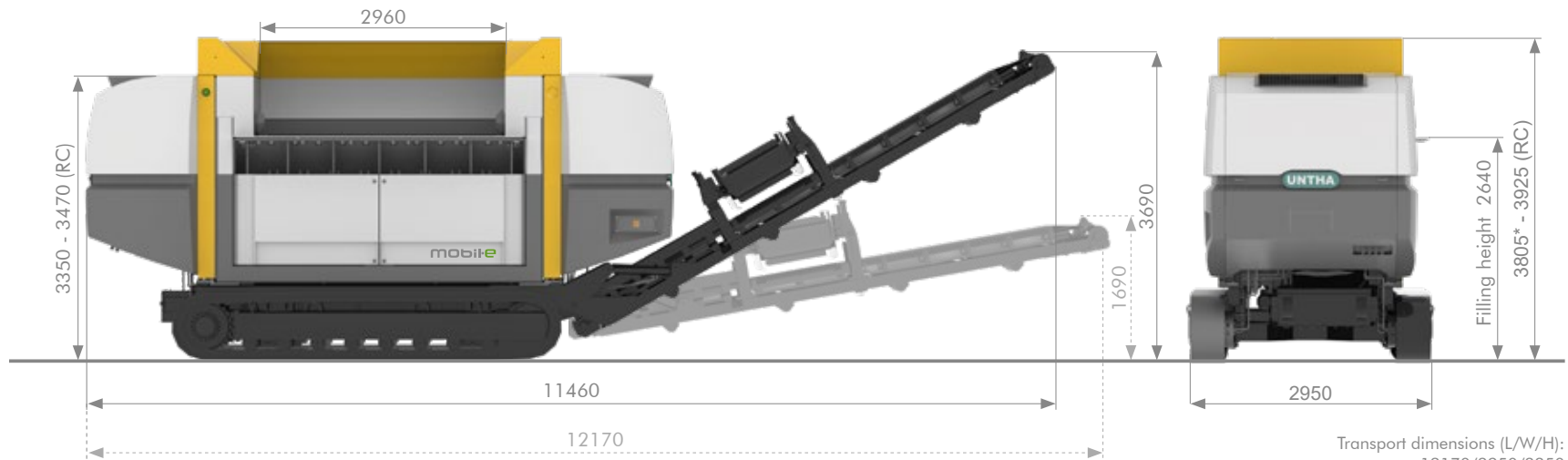

Transport dimensions (L/W/H):
12170/2950/3350
*) with hopper attached

XR system solution



All dimensions in mm



Put us to the test!

No challenge is too big for our XR shredders:

- » Industrial and commercial waste
- » Waste wood
- » Metal
- » Material that is notoriously difficult to shred (pulper ropes, rolled goods)

See for yourself, during a live demonstration at your premises.

Book a slot now at www.untha.com/demo!

The best testimonials **worldwide**

Many top-level companies already trust in the reliable UNTHA brand. See here for a selection of our international customers.



See more customer success stories at marketing@untha.com!

UNTHA shredding technology GmbH

Kellau 141/ Salzburg, Austria
A-5431 Kuchl
Tel.: +43 6244 7016 0
Fax: +43 6244 7016 1
info@untha.com
www.untha.com

UNTHA Deutschland GmbH

Am Hammersteig 5a
D-97753 Karlstadt
Tel.: +49 9353 906869-0
Fax: +49 9353 906869-35
info@untha.de
www.untha.de

UNTHA UK Ltd.

Excel House, Becklands Close
Boroughbridge
YO51 9NR
United Kingdom
Tel.: +44 845 4505 388
Fax: +44 845 4505 389
sales@untha.co.uk
www.untha.co.uk

UNTHA America, Inc.

1 Lafayette Road, Building 4
Hampton, NH 03842
Tel.: +1 603 601 2304
Fax: +1 603 601 7573
info@untha-america.com
www.untha-america.com

UNTHA Polska Sp. z o.o.

Olecka 23/221
04-980 Warszawa / Polska
Tel.: +48 12 6421896
Fax.: +48 12 6421896
info@untha.pl
www.untha.pl

UNTHA Ibérica S.A.

Polígono de Sigüeiro - Parcela 58, Sigüeiro - Oroso / A
Coruña / España
Tel.: +34 981 69 10 54
Fax: +34 981 69 08 78
info@untha-iberica.com
www.untha.es

5 reasons to choose UNTHA



Customised, long-lasting shredding solutions



Premium quality products and services



All-encompassing expertise, from development to production, under one roof



Reliable customer service with the best technical know-how



More than 10,000 satisfied reference customers worldwide

We deliver what we promise

Since our founding in 1970, we've followed our promise of being "the reliable brand", which applies to every product and service that UNTHA delivers.

We work hard to consistently outperform our competitors, and provide customers with the confidence that – in choosing UNTHA – they have made the best decision for their business.