

GYPSUM RECYCLING SYSTEM

- a solution designed to handle different waste streams,
as well as different contaminants

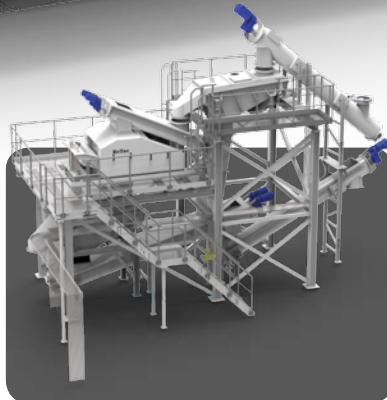

- a strong solution for the environment



GYPSUM RECYCLING SYSTEM

Your partner in Gypsum Recycling

ReTec is amongst the pioneers in the development of Gypsum Recycling. Having built and co-developed the first mobile plants in 2000, we have always been at the forefront of the industry. Our approach is simple: we listen to the customer, we analyze the material carefully, and we develop our solutions to match the needs – and nothing more.

Modular solution for different waste streams

Waste is heterogeneous. Therefore our solution is designed to handle different waste streams, as well as different contaminants.

For construction & demolition plasterboard waste, we design a pre-treatment process that crushes the plasterboards and removes as much of the contaminants as possible.

For the cleaner production waste the pretreatment is primarily size reduction for the material to enter the roller-mil.

The roller-mill is constructed with a moveable roller that will allow con-

taminants like wood, hard plastics etc. to pass through the mill. The roller-pressure is applied through a simple and reliable mechanical principle of springs.

For screening, we use a conventional single deck vibration screen with rubber balls. Capacity and screen-size according to customer needs.

For transport of gypsum powder in the plant we use closed screw-conveyors.

For onwards handling of the out-put fractions of gypsum powder and

waste (mainly paper) we offer different solutions such as a screw-press attached to a container to eliminate manual handling process, which is time consuming and dusty.

High quality separation

We work with several key parameters to ensure a good quality of separation:

- Pre-treatment process removes contaminants and reduces particle size to < 50 mm, without cutting the paper into fines that are difficult



to screen afterwards and therefore will increase your unwanted TOC%

- The roller-mill while applying a lot of pressure will very efficiently “grind” the gypsum of the paper, hence reducing unwanted gypsum in your waste-fraction (cost of incineration or land-fill).

The efficiency of your separation dictates the quality of your product. With the ReTec Gypsum Recycling solution you get state-of-the-art quality outputs:

- Clean gypsum powder with very low TOC
- Waste paper fraction with very little Gypsum content

High reliability and low operating cost

We design our equipment as simple and reliable as possible, and avoid not needed complexity.

For example, the pressure force on the rollers is applied mechanically by means of springs - a strong, simple and reliable construction. Therefore our customer feed-back tells us of very high plant reliability.

Your turn-key supplier

ReTec offer our solution on turn-key basis. We have in-house construction department, electrical engineering and project management. We manufacture at our own facility in Haderslev, Denmark. We offer installation and commissioning and our own experienced service technicians.

References

Our references include a number of Gypsum Recycling Operators in Northern Europe as well as Plaster-board manufacturers. Please contact us for more information.

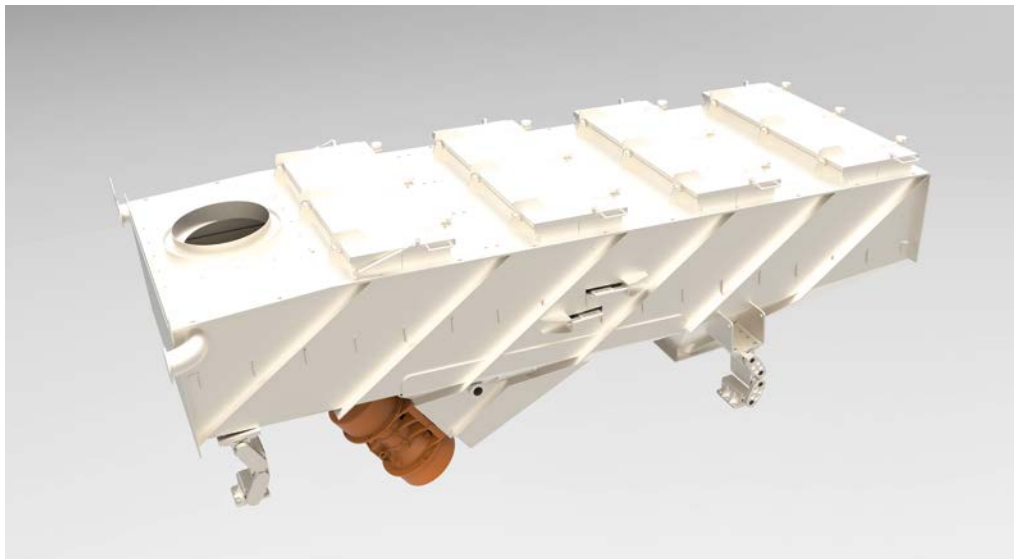
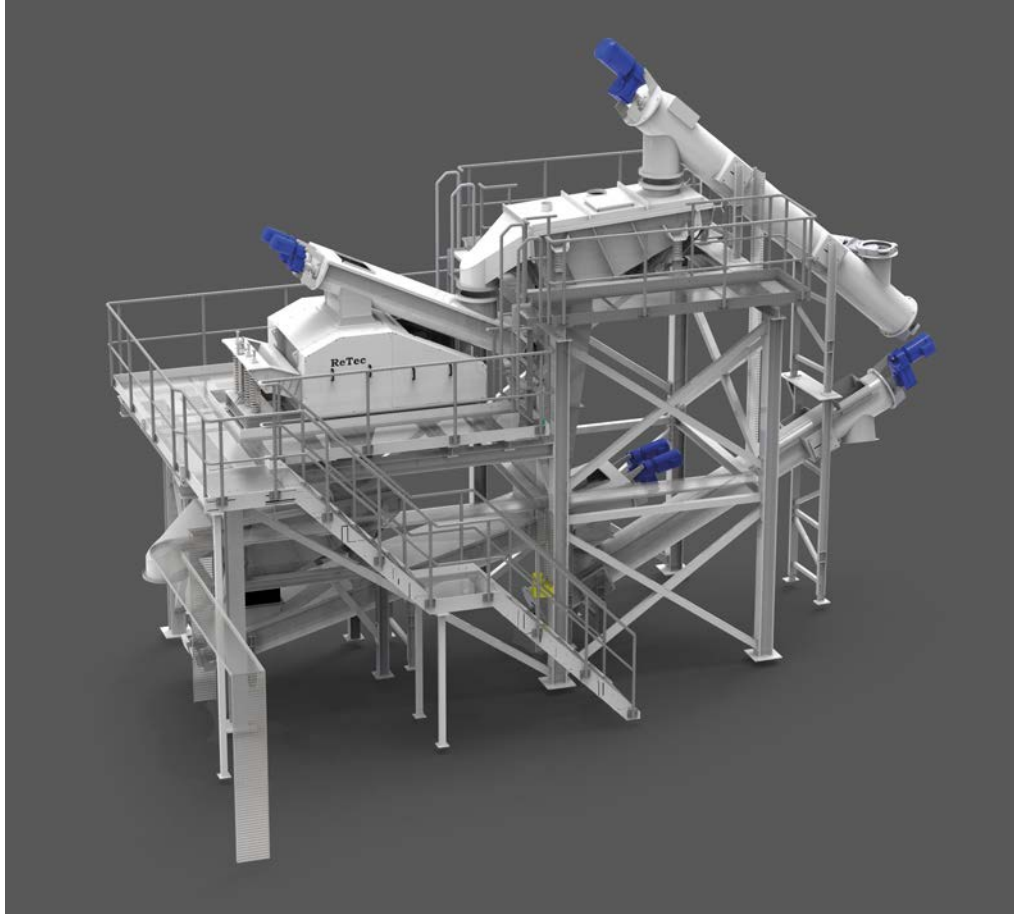

Gypsum Recycling Mill

Technical specification:	Gypsum Recycling Mill - RGV 22/1000
Power:	1 pcs. 22 kW motor with pull on fixed rollers
Start:	Electric motor starts via Star/Delta
Infeed opening:	900 x 500 mm
Rollers:	<ul style="list-style-type: none"> • Ø 600 mm x B 1000 mm. • 1 pcs. Fixed roller. • 1 pcs. Spring-loaded moveable roller (opens up to 50mm). • Adjustable between 5 – 10 tons pressure between the rollers.
Outlet:	Flange 1000 x 500 mm
Capacity:	Approx. 10 tp/h
Weight:	Approx. 4500 kg

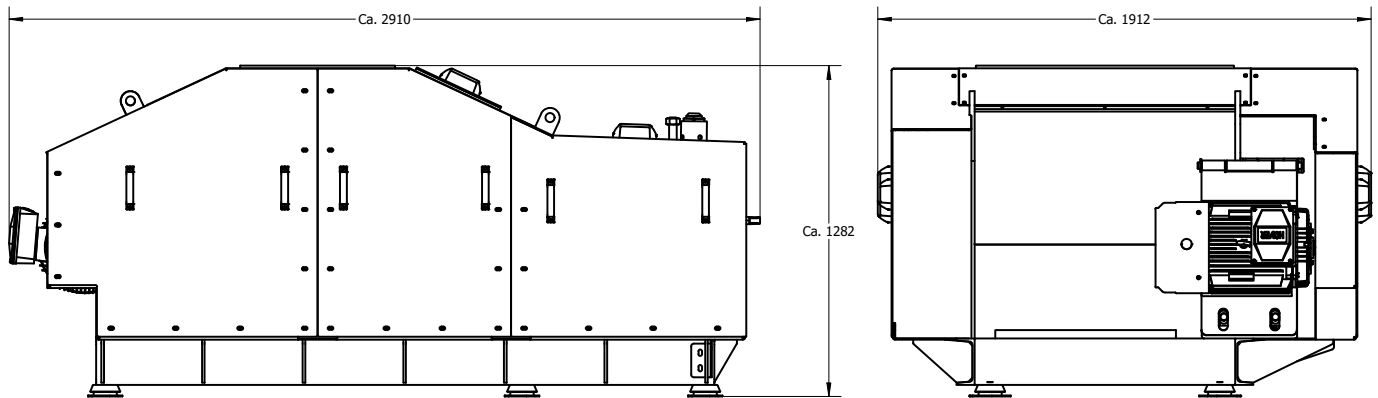

Vibration Sieve - RVS D150/2200

Technical specification:	Vibration Sieve - RVS D150/2200
Measurements:	L: 4336 mm, W: 1919, H: 1824 mm.
Incline:	5°.
Weight:	Approx. 3000 kg.
Power:	2 pcs. 4,3 kW vibration motors.
Sieve area:	2 x 3 m ² = 6 m ² in two levels.
Sieve opening:	Sieve screen (stainless steel 304) squares 5x5 mm diagonally approx. 7 mm.
Optional: Cleaning system:	Bouncing balls in a basket under net, 84 or 112 balls.
Quality of steel:	The Vibration sieve is built in the steel quality S355JR.
Cover plates:	4 pcs. For inspection and change of net.

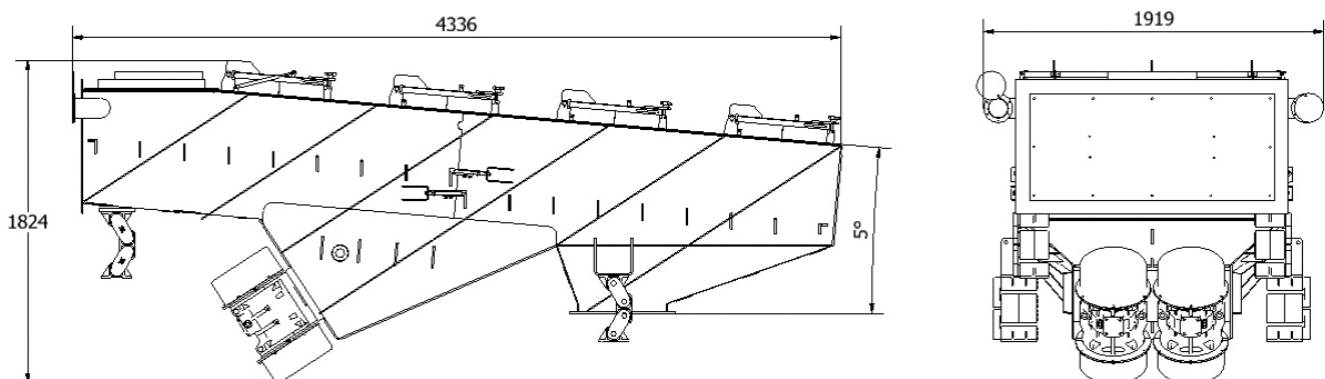

ReTec Miljø ApS
Fjordagervej 38
DK-6100 Haderslev

Tel.: +45 7456 8106
Fax: +45 7456 8581
VAT: DK 25 86 24 22

sales@retec.dk
www.retec.dk

ReTec develops, constructs and manufactures special machines for the waste and recycling industry. We offer practical solutions to our customer's needs, helping them increase profitability in their business.